

ELECTRONICTM

Servicing & Technology

SEPTEMBER 1985/\$2.25



Servicing VCRS – part 2 • The video connection – part 4

Blowing misconceptions about fuses

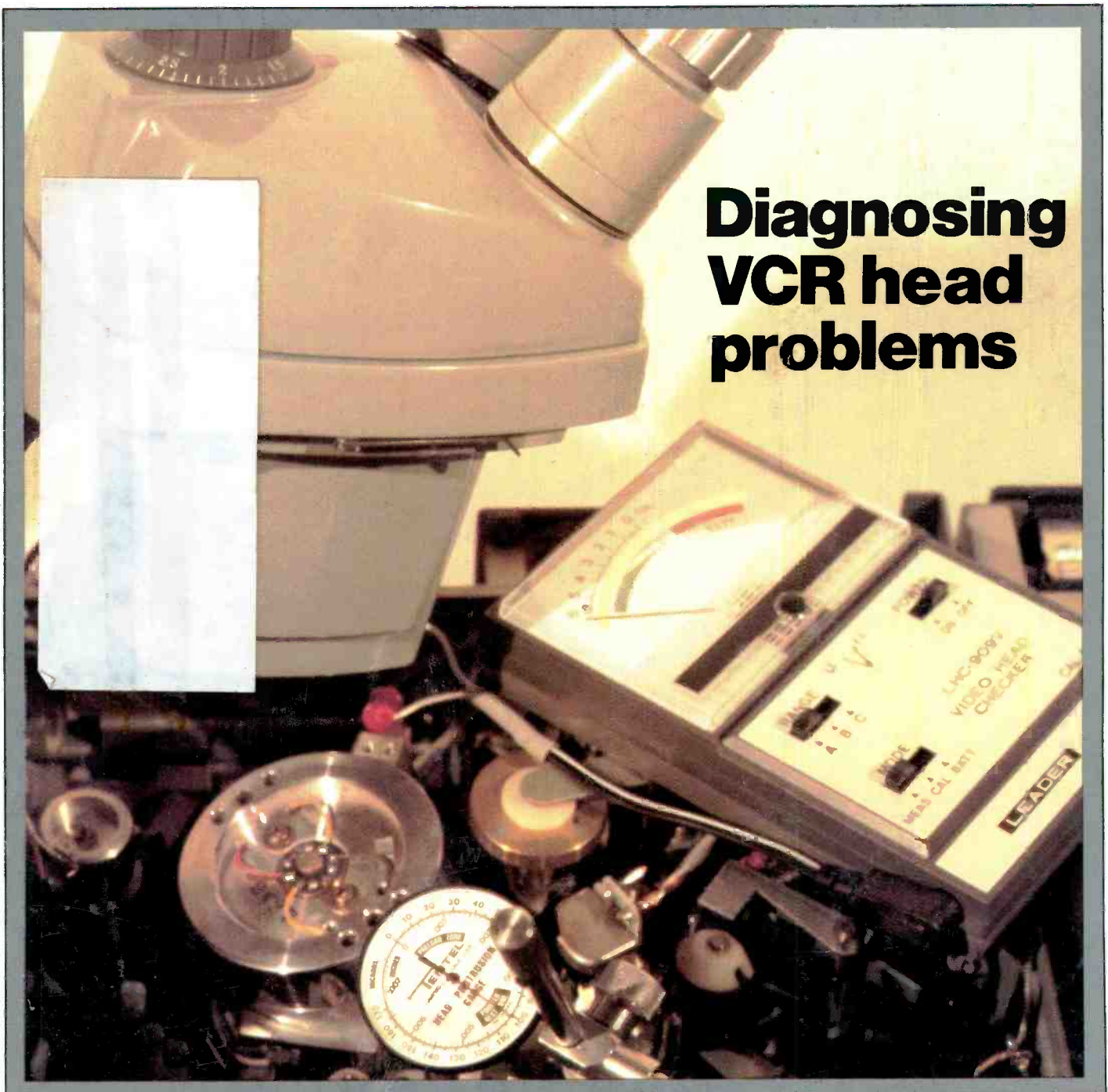

Diagnosing VCR head problems



LOOK! ZENITH ACCESSORIES!
 It's about time you make some extra money
 in the service business!



There are millions out there! Millions and millions of people with cash in hand looking for the easiest, fastest, most reliable way to tie their television sets to the mind-boggling variety of functions and program sources now available.

That's why industry forecasters point to this year, 1985, as the year the market for video-audio accessories really comes of age.

And who's the most likely to profit – of all the people in the industry! – from this booming bonanza in the television aftermarket? You are. The Service Center electronic technician, that's who.

You can be johnny-on-the-spot with the perfect Zenith accessory to fulfill your customers' needs whether you're in the shop or out on a service call.

Imagine what a market for accessories some eighty-five million TV households in the U.S. represent! In terms of units...and dollars. 85,000,000! What a market for Zenith's push-button television control center, the Organizer. For indoor and outdoor antennas. For VCR tapes, both VHS and Beta.

What a market, too, for Zenith Spike Suppressors. For lightweight stereo-phones. And for all the other video,

audio, and telephone connectors and convenience devices your Zenith distributor now has on hand for you, including Zenith's new Stat-Attack™ Cleaning System.

Actually, this is the biggest, broadest line of Zenith electronic accessories ever backed by a name renowned for product performance and reliability.

Make the most of it! Call your Zenith distributor's Parts & Accessories Sales Manager now, today. It's about time you start making some extra money in the service business. With Zenith Video-Audio-Telephone accessories, of course!

Zenith Service, Parts & Accessories • 11000 Seymour Avenue, Franklin Park, Illinois 60131 • A Division of Zenith Electronics Corporation



The technology is advanced. The temperature stays put.



EC 1000
Dial controlled with EC1201P iron.

EC 2000
Three digit LED readout with EC1201P iron.

EC3000
Dial controlled with lightweight EC1301 soldering pencil.

EC 4000
Three digit LED readout with lightweight EC1301 soldering pencil.

All EC Series stations meet Mil-spec DOD-STD-2000-1

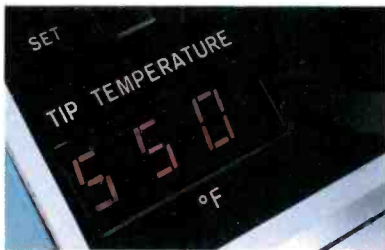

When you need controlled output soldering for sensitive components, you don't need uncontrolled temperature fluctuations at the work station. In the Weller EC Series, the tip temperature is maintained throughout the range of 350°F – 850°F to within 10°F. In addition, an electronic system utilizes thyristor power control with zero voltage thyristor drive. This

ensures that no high voltage spikes or magnetic fields will be present on the soldering tip.

These technologically advanced stations are capable of handling all the delicate soldering operations necessary, in even the most sophisticated applications. They offer the ultimate in soldering flexibility with a choice of controls and readouts to suit your needs precisely.

Check with your Electronics Distributor.

Weller® EC series



CooperTools

The difference between work and workmanship.

BOKER® CRESCENT® LUFKIN® NICHOLSON® PLUMB® WELLER® WISS® XCELITE®
The Cooper Group PO Box 728 Apex NC, 27502 USA Tel (919) 362-7510 Telex 579497

Circle (4) on Reply Card

www.americanradiohistory.com

ELECTRONIC

Servicing & Technology

Volume 5, No. 9 September 1985

10 Test your electronic knowledge

By Sam Wilson

Names in the game may throw you, otherwise aim for 100 percent in this easier-than-usual electronics quiz.

12 Servicing videocassette recorders, part two

By Neil Heller

Last month's theory becomes this month's practical application when troubleshooting VCRs, with warnings to avoid shotgun diagnoses that create new problems.

Departments:

- 4 Editorial
- 6 Technology
- 9 News
- 52 Symcure
- 62 Troubleshooting Tips
- 63 Books
- 64 Products
- 66 Readers' Exchange
- 68 Literature

22 Diagnosing VCR head problems

By Wayne B. Graham

Electronics-oriented technicians are advised to think mechanical as they approach ailing VCRs: VCR heads are mechanical components that are subject to wear and, therefore, susceptible to failure.

48 What do you know about electronics? Blowing misconceptions about fuses

By Sam Wilson

If the statement "There is no amount of current in the world that can cause a fuse to blow" blows your mind, then read what really happens, and why there can be an arcover, even after the fuse is blown. Also, the author initiates an ongoing discussion about noise.

54 The video connection part four

By Martin Clifford

For the beginner, or for the veteran TV technician who reinforces his knowledge by periodic reviews, this series of articles makes it easier to connect those add-ons and TV multiples demanded by modern households and small-to-medium businesses.



Diagnosing VCR head problems, page 22
Photo: courtesy of Tentel, Campbell, CA.

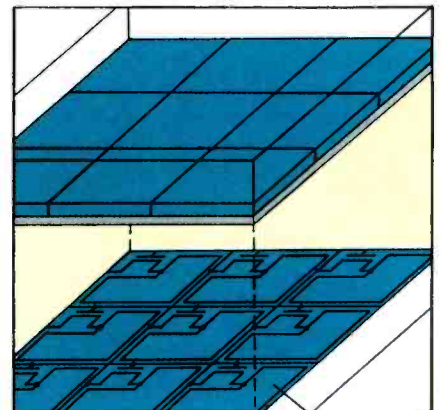

Eliminating the polarizer represents one more step in the development of large, flat-screen televisions. Page 7.

New from B&K-PRECISION, for telephone service, test and repair

COMPLETE TELEPHONE PRODUCT ANALYZER. A total self-contained system for diagnostic testing, servicing and calibration of corded and cordless telephones, answering machines and automatic dialers. Performs every test you'll ever need to test and repair any phone product including verification of pulse and touch-tone numbers, measurement of frequency error and modulation deviation. **MODEL 1050 \$1695**



MODEL 1050 \$1695

CORDLESS TELEPHONE TESTER. Provides full servicing and calibration capability for base and portable phone units. All rf test and measurement functions. Replaces expensive FM generators and modulation monitors, yet performs all tests required for cordless phone system analysis and repair, including full frequency testing and alignment. Generates carrier and recently approved frequencies. **MODEL 1047 \$895**



MODEL 1047 \$895



MODEL 1045 \$395

TELEPHONE PRODUCT TESTER. For in-store consumer or service use. Tests handset cord, phone line cord, dial/redial functions, voice and dial number levels, ring function and voice quality of corded and cordless phones, answering machines and automatic dialers. **MODEL 1045 \$395**



MODEL 1042 \$19.95

TELEPHONE LINE ANALYZER. Quickly identifies a problem as external or in the phone itself. Tests for condition of external phone line, phone line cord, ring and line voltage levels and polarity. Easy to use, no batteries or external power needed. **MODEL 1042 \$19.95**

These test instruments cover every possible level of service required for telephone products. They are equally useful for training. The instruction manuals provided offer a comprehensive course of training for service personnel and students. Call your nearest B&K-PRECISION distributor for off-the-self-delivery or additional information—or contact B&K-PRECISION.

B&K PRECISION DYNASCAN CORPORATION

6460 West Cortland Street • Chicago, Illinois 60635 • 312 889-9087

International Sales: 6460 W. Cortland St., Chicago, IL 60635

Canadian Sales: Atlas Electronics, Ontario

South and Central American Sales: Empire Exporters, Plainville, NY 1203

Circle (5) on Reply Card

September 1985 *Electronic Servicing & Technology* 3

Get a scorecard, learn what's going on

Today is perhaps the most eventful, most exciting time in the brief history of television broadcasting and reception. So many things have happened recently, so many things are happening now and so many things are in progress that will unfold in the future that it's difficult to keep track of all of them.

But things that are happening right now are going to affect profoundly just about everyone who has any stake in television in any way, for now, and for many years to come; everyone, including viewers, programmers, people who sell and service televisions, legislators.... What will be affected are such things as what programming will be available and from what sources, how much it will cost, what broadcast media will be used to get it to the TV set, what picture and sound quality will ultimately be available, who will sell and service TV sets, and much, much more.

Here are some of the variables in the stew right now, in no particular order:

- The number of sources of TV programming has gone from one—the local VHF/UHF broadcast stations—to a mind boggling mix: broadcast stations, cable, TVRO, VCR, videodisc.
- Currently being experimented with or proposed are at least two other program sources: DBS (Direct-Broadcast Satellite) and MDS (Multiple Distribution Service). MDS is an over-the-air pay system that uses currently unused frequencies to broadcast premium programming.
- High-definition TV is under development. There are many obstacles to be overcome, not the least of which is the broad bandwidth required, but eventually it may be possible to receive TV signals with twice the resolution currently achievable.

- LCD television has already made the shirt-pocket television a reality. Under development at this moment are large-size thin LCD televisions that soon may lead to the hang-on-the-wall television.

- Stereo TV is a reality. Anyone now can buy a television with stereo reception capability, and in some areas stereo broadcasting has started.

Those are some of the technological developments. There are many more. In the policy-making, marketing and legislative arenas a great deal has happened and *will* happen concerning television that may have as great or even greater impact on viewers, servicers and providers of TV programs. Recently legislation was passed that may allow cable TV system operators to sell and service TVs. It is the contention of organizations of independent servicers that this gives monopoly advantage to the cable companies. In some states, electric power companies are looking into the possibility of selling and installing TVRO systems, using their financial strength and existing billing systems to enable consumers to buy a TVRO system from the power company and pay for it over a period of years on their monthly power bill.

A great deal is happening in the area of television and video; not all of it necessarily accruing to the advantage of viewers, servicers or the general public. If you're not already keeping abreast with what's going on, and telling your legislator, manufacturer and programming providers what you think about it, perhaps you should. A great deal is going to be happening in the next few years. You should have a voice in it.

Nils Conrad Persson

ELECTRONIC

Servicing & Technology

Editorial, advertising and circulation correspondence should be addressed to: P.O. Box 12901, Overland Park, KS 66212-9981 (a suburb of Kansas City, MO); (913) 888-4664.

EDITORIAL

Nils Conrad Persson, *Editor*
Carl Babcoke, *Consumer Servicing Consultant*
Rhonda Wickham, *Managing Editor*
Marjorie Rigglin, *Associate Editor*
Dawn Hightower, *Editorial Assistant*

ART

Kevin Callahan, *Art Director*
Jonl Harding, *Graphic Designer*

CIRCULATION

John C. Arnst, *Director*
Evelyn Rogers, *Manager*
Dee Manles, *Reader Correspondent*

ADMINISTRATION

R. J. Hancock, *President*
Cameron Bishop, *Publisher*
Eric Jacobson, *Associate Publisher*

ADVERTISING

Greg Garrison, *National Sales Manager*
Julie Roberts, *Production Manager*
Stephanie Fagan, *Marketing Coordinator*
Kelly Hawthorne, *Marketing Assistant*



Member, Audit Bureau
of Circulation



Member, Association
of Business Publishers

ELECTRONIC SERVICING & TECHNOLOGY (USPS 462-050) (with which is combined Electronic Technician/Dealer) is published monthly by Intertec Publishing Corp., 9221 Quivira Road, P.O. Box 12901, Overland Park, KS 66212-9981. Second Class Postage paid at Shawnee Mission, KS 66201. Send Form 3579 to P.O. Box 12952, Overland Park, KS 66212-9981.

ELECTRONIC SERVICING & TECHNOLOGY is the "how-to" magazine of electronics. It is edited for electronic professionals and enthusiasts who are interested in buying, building, installing and repairing home-entertainment electronic equipment (audio, video, microcomputers, electronic games, etc.).

SUBSCRIPTION PRICES: one year \$18, two years \$30, three years \$38 in the USA and its possessions. Foreign countries: one year \$22, two years \$34, three years \$44. Single copy price \$2.25; back copies \$3.00. Adjustment necessitated by subscription termination to single copy rate. Allow 6 to 8 weeks delivery for change of address. Allow 6 to 8 weeks for new subscriptions.

PHOTOCOPIY RIGHTS: Permission to photocopy for internal or personal use is granted by Intertec Publishing Corp. for libraries and others registered with Copyright Clearance Center (CCC), provided the base fee of \$2 per copy of article is paid directly to CCC, 21 Congress St., Salem, MA 01970. Special requests should be addressed to Cameron Bishop, publisher.
ISSN 0278-9922 \$2.00 + 0.00

INTERTEC
PUBLISHING CORPORATION

©1985 All rights reserved.

SEE THE LATEST HIGH TECHNOLOGY SOLDERING TECHNIQUES DEMONSTRATED ON VIDEOCASSETTE!

Keep up to date with the newest techniques for soldering integrated circuits and chip components with this 15-minute, information-packed videocassette prepared by the Electronic Industries Association/Consumer Electronics Group.

Produced under the supervision of professional electronics technicians and engineers from leading electronics manufacturers, the tape focuses up close on actual work bench situations. It shows you the latest tools and equipment... and step-by-step it demonstrates proper soldering techniques, showing you how to work more quickly, safely and efficiently while servicing even the most sensitive electronics products.

Produced by EIA/CEG as a service to the industry, the tape is available for only \$15—one of the best investments you can make to stay on top in your own work or to train others in the rapidly changing electronics field.

**Send in the coupon for your cassette today to
EIA/Consumer Electronics Group
Dept. PS, P.O. Box 19100
Washington, D.C. 20036**

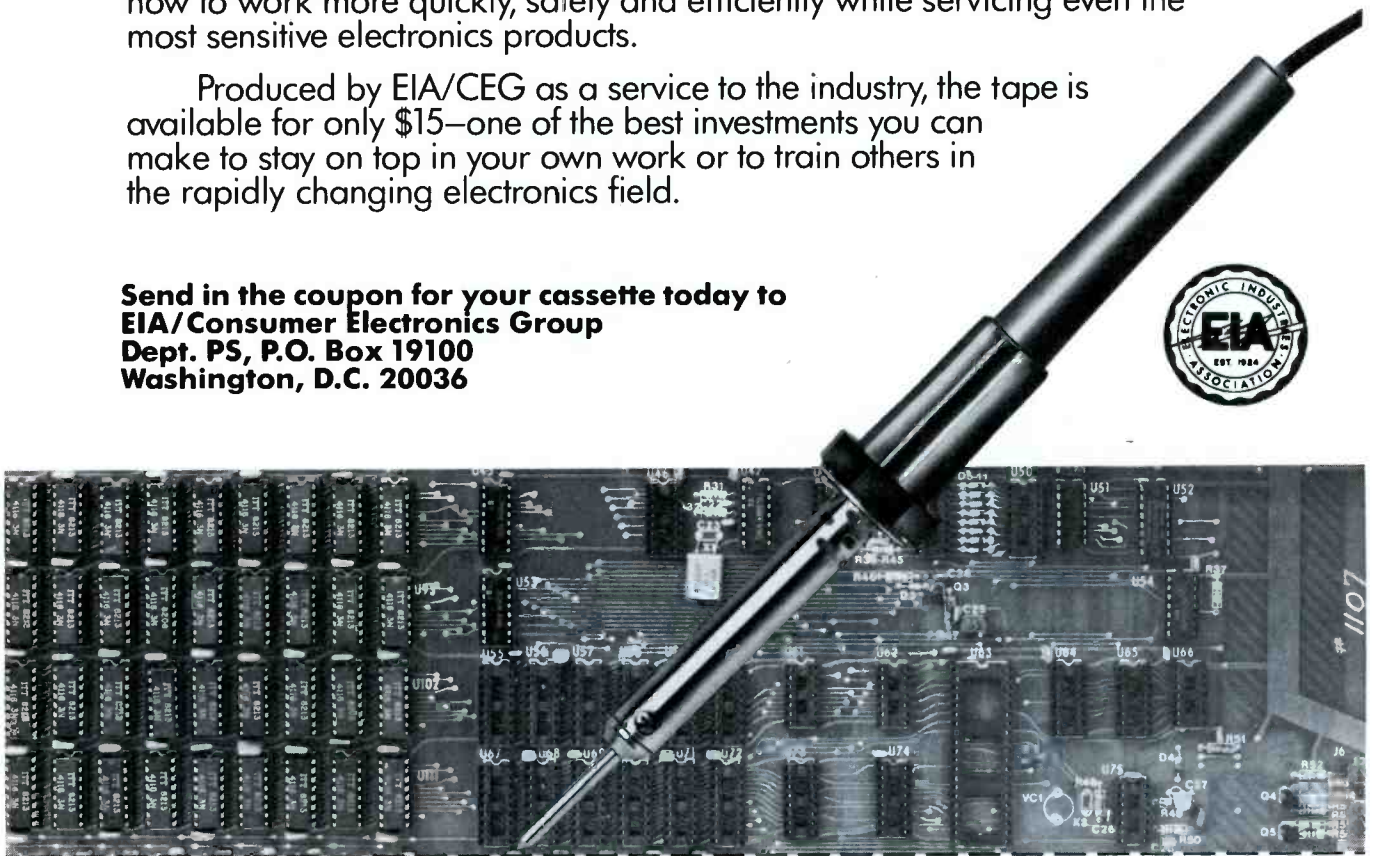

**Make check or money order payable to
Electronic Industries Association.**

**Please Send Me
The EIA/CEG
High Technology
Soldering Tape @ \$15 prepaid.**

- VHS FORMAT
 BETA FORMAT

QUANTITY

TOTAL
\$

NAME _____

COMPANY _____

STREET _____

CITY _____ STATE _____ ZIP _____

Circle (6) on Reply Card

New laser device advances fiber-optic technology

Fiber-optic cables are capable of carrying hundreds of TV channels or thousands of telephone conversations. The device that converts the electronic signals into light signals which are then transmitted via fiber-optic cable is the solid-state laser.

RCA has announced the development of a laser device that is expected to have important applications in the fields of space communications, fiber-optics communications and optical processing.

The unit is considered a major step in simplifying the manufacture of more reliable solid-state

lasers that operate at a single, stable wavelength. These are required today in many areas of electronics and particularly in fiber-optics communications that use a cable made of glass fibers about as thick as a human hair.

"The recent explosion in fiber-optics communications has led to more stringent demands on lasers, including stabilization of the wavelength," says Dr. Bernard Hershenov, director, optoelectronics research at RCA laboratories. "Lasers with stabilized wavelengths will be required in space and terrestrial communications, as

well as in the emerging areas of optical computing and data storage."

Called an external Bragg reflecting laser (EBRL), the device provides greater reliability and improved performance than previous lasers of the same type.

Solid-state diode lasers exhibit wavelength changes because of temperature, power-level changes and the pulsating laser driving currents required to put information on the light beam, according to Dr. Hershenov. Many companies are actively pursuing methods to minimize these changes by modifying the lasers themselves. However, the growth of these modified lasers is a tightly controlled process that is complicated further by these modifications.

Simplifies manufacturing

The scientist said the new EBRL has demonstrated, for the first time, wavelength stabilization using an external waveguide structure containing a reflective grating and made of a different material than the laser itself. This technique avoids complicating the growth process and simplifies manufacturing. Also, it has the advantage of allowing off-the-shelf diode lasers to be combined with off-the-shelf waveguide units to achieve stabilization at a desired wavelength.

The advantage of this approach is that it allows optimized and well developed high power diode lasers to be combined with optimized waveguide structures which provide the required reflection. The external waveguides also may be used to shape the output light beam and to assist with coupling the light into optical fibers.

When the laser is operated with a stream of pulses, as would be done for a communication system, the light output is observed to remain at single wavelengths over a wide range of output powers and operating temperatures. **ES&T**



Research-team leader Dr. Jacob Hammer examines the EBRL device.

Another step toward large, flat-screen televisions

Engineers have recently made progress in the development of large-sized full-color displays, leading to the conclusion LCDs may become more practical for applications such as miniature televisions and computer terminals. These new developments were reported at the 1985 Society of Information Display (SID) conference in April in Pensacola, FL.

All color liquid crystal displays (LCDs) require backlighting to make the displayed image clearly visible in normal room light. In the past, the amount of backlighting required has limited the usefulness of these compact displays in a number of applications. Recently, research at Epson/Suwa Seikosha's LCD R&D group into phase-change guest-host (PC-GH) liquid crystals has resulted in displays that make better use of available light. These PC-GH displays require less backlighting than previous types of LCDs and therefore consume less power and are more reliable. They also can be manufactured at a lower cost.

The research project has resulted in improvements in three distinct areas:

1. The elimination of a polarizer.
2. Better selection of dyes for color filters.
3. A 2-frequency active-matrix driving technique.

Improving brightness

In creating a display, liquid crystal is held between two glass plates. On one plate, is a common electrode; on the other plate, are electrodes that control the state of each pixel picture element individually. In its *off* state, a liquid crystal can rotate incoming light by 90 degrees, polarizing the light, but not blocking it. In the past, to create an image, a polarizer was placed in front of the display to cross-polarize this light, creating the dark dots of the image.

In creating these new PC-GH

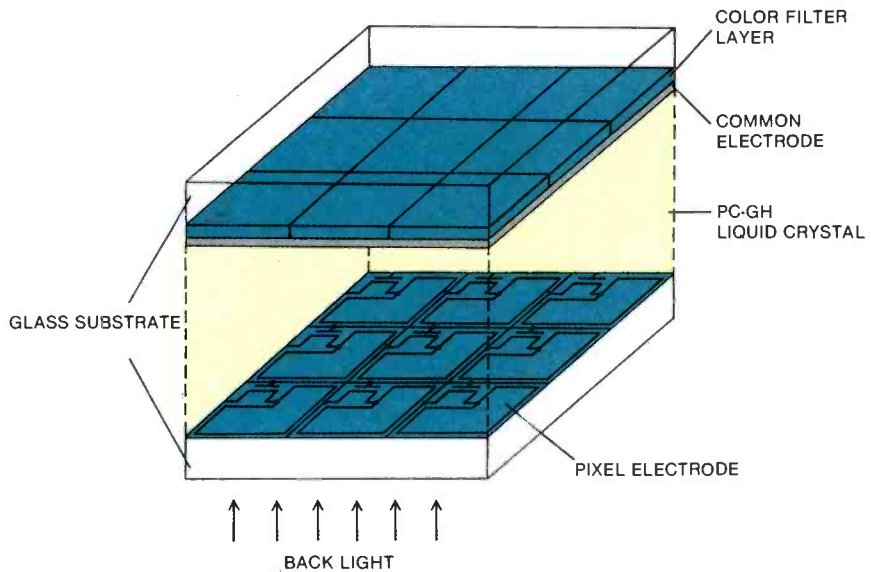

Figure 1. Introduction of dye into liquid crystal held between two glass plates permits elimination of polarizers previously used in LCD displays.

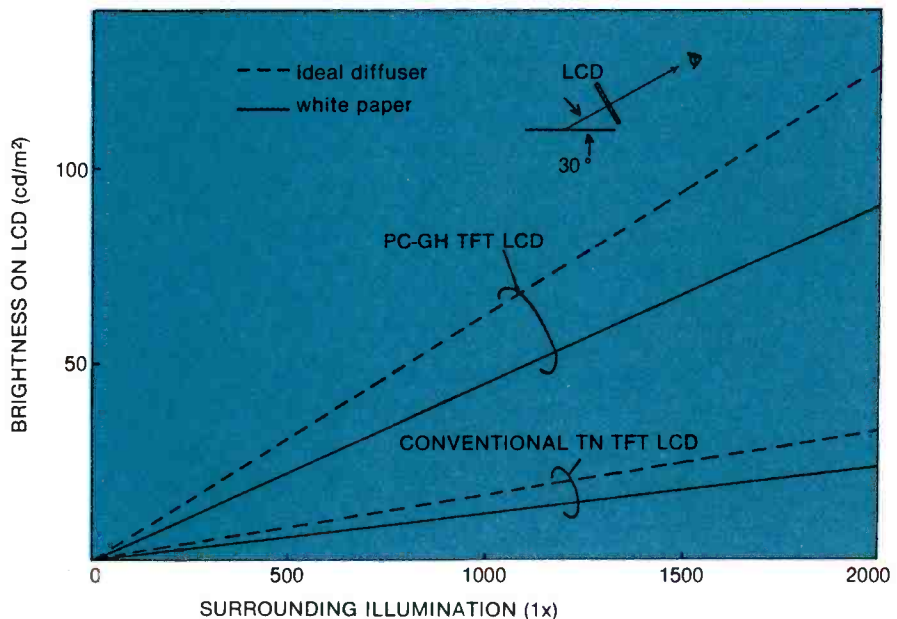

Figure 2. Less backlighting is needed, the viewing angle is widened sans polarizer.

displays, engineers have introduced a dye as a guest material (the liquid crystal itself is the host material). In its *off* state, that same orientation of the crystals that polarizes the light in other displays also will align the dye molecules in a way that actually blocks light from passing through

the pixel. The polarizer isn't needed.

Eliminating the polarizer is a significant step toward development of reasonably priced LCD packages. The polarizer is an inefficient device. As much as 60 percent of the light passing through it can be lost. To compensate for this

light loss, LCDs that use polarizers require intense backlighting. Eliminating the polarizer means that PC-GH LCDs will require far less intense backlighting, be more energy efficient and cost less to make. As an added benefit, eliminating the polarizer widens the display's viewing angle—you don't have to look straight on at the display to see the picture properly.

The color filter plays an important role in picture brightness, and the green dots (pixels) on a display contribute more to brightness than either red or blue. Special dyes for the color filters that pass green better than other colors have been selected. Additional research into dye selection has improved the amount of red and blue light that also would pass through the filter. These new filters are made exactly the same way that the old filters were, but they transmit 60 percent more visible light.

Improving the contrast

Increasing the amount of transmitted light is only part of the battle, however. The contrast ratio (the ratio of the amount of light that leaks through when a pixel is *off* compared to the light transmitted when it is *on*) plays an important role in the displayed image's visibility. Unfortunately, the PC-GH LCD has less contrast than other types of LCDs. This had to be overcome to make the display practical.

Epson/Suwa Seikosha's R & D group has developed a 2-frequency active matrix driving technique that switches the display from *on* to *off* quickly and improves its contrast ratio. The matrix consists of 480x440 thin-film transistors (TFTs) that actually drive the individual pixels. Giving each pixel its own active driver (fabricated right on the back sheet of glass inside the display) makes the panel

more compact and eliminates the need for the interface electronics required by multiplexed displays.

A high-frequency signal (10kHz) erases images already displayed, and a lower-frequency signal provides data for the next image. Without the erasing signal, it would take 40ms to turn *off* a pixel that was *on*; the erasing pulse shortens that time to 25ms. In addition to driving the pixel *off* faster, the erase signal also shuts the pixel *off* more completely, improving the contrast ratio. The improvement in contrast that the driving method provides, coupled with the PC-GH display's increased brightness, makes the display package better suited for use in room light. More research is under way to further develop the contrast ratio of large display and to eliminate backlighting.

ES&T

Single chip stops voltage transients and current surges

A monolithic protection device capable of suppressing both transient overvoltages and high current surges has been introduced.

The L3100, manufactured by SGS Semiconductor Corporation, is the first device that combines transient overvoltage/overcurrent

suppression on a single chip, according to Serban Coss, linear product marketing manager. It also is the first device to provide total protection without any secondary protection devices, Coss adds.

The IC is designed primarily for

use in telecommunication circuits, such as SLIC cards, telephones.... Its purpose is to guard against transients caused by lightning, induction from power lines and power-line short circuits.

The protection circuit is triggered by current as well as voltage surges. Also, these parameters are programmable using only two external components.

Connected in parallel with the load to be protected, the device remains in a high-impedance *off* state. Leakage is only 10 microamps at 280V.

When current or voltage thresholds are exceeded, the L3100 quickly switches to the *on* state (approximately 100ns) to become a short-circuit path for the transients. In this condition, the circuit is capable of withstanding up to 200A of peak current and repetitive sine-wave peaks of up to 20A.

Below the holding current level (about 250mA), the L3100 returns automatically to the *off* state. The holding current is high enough to allow automatic recovery even on lines carrying a remote dc supply current.

ES&T

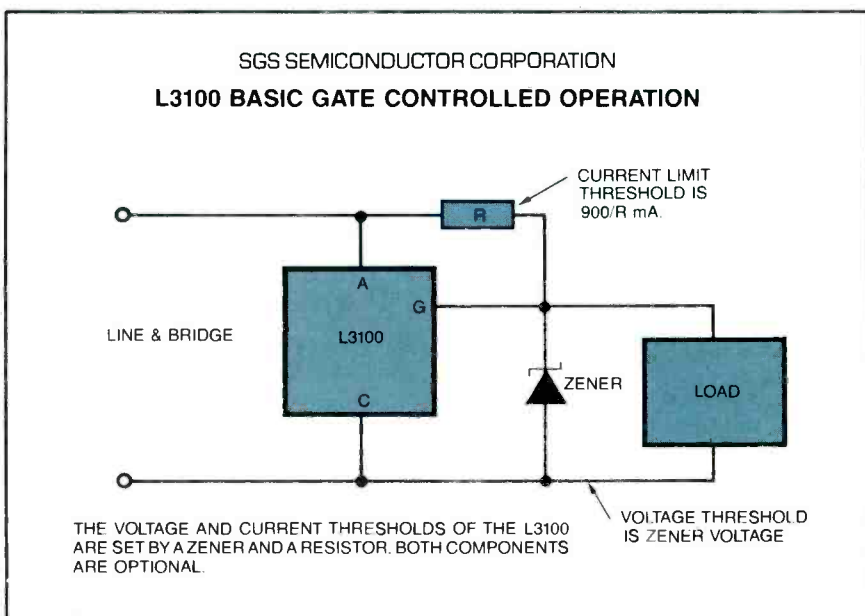

Figure 3. The L3100 IC can suppress transient overvoltages, high current surges.

Videotape on careers in electronics

The Electronics Industries Association has completed production of "Inventing the Future," a 15-minute videotape geared toward young people to make them aware of the vast number of career opportunities available in the electronics industry if they have sufficient preparation in the fields of mathematics and science.

Tom Patton, director, Human Resources Council (HRC), said in announcing the availability of the tape, "This production is another step in EIA's program to assure an adequate supply of trained personnel to meet the long-range needs of our growing industry."

The new program features interviews with NASA astronaut Judith Resnik and Apple Fellow Dr. Allan Kay, as well as a number of people with technical positions in the electronics industry.

The videotape was produced for use by EIA members as part of their communications and community relations programs.

It is currently available in 1/2-inch and 3/4-inch (VHS) videotape formats. To cover costs of production and distribution, each tape will cost \$100. Quantity discounts are available.

Order "Inventing The Future" by contacting Tom Patton, Electronic Industries Association, 2001 Eye St., N.W., Washington, DC 20006; 202-457-4925.

Home video products looking up

Led by videocassette recorders, sales of most video products increased both in June and during the first half of 1985, according to figures compiled by the Electronic Industries Association's Consumer Electronics Group.

Data compiled by EIA's marketing services staff indicate that sales of VCRs rose nearly 58 percent last month to about 980,000 units—the third best sales month in the product's history. First-half VCR sales topped 4.7 million units,

62 percent above the first six months of 1984. EIA's Consumer Electronics Group has predicted that 11.5 million VCRs will be sold during 1985, as compared with 7.6 million last year. (*Editor's note: See ES&T August 1985 "News" regarding curtailed shipments of VCRs that, uncurtailed, would have exceeded anticipated sales by approximately 3.5 million.*)

Color television enjoyed a solid sales month in June, rising 13 percent relative to the same month a year ago. Six-month sales of color televisions amounted to nearly 7.4 million units, up fractionally over their record pace in 1984. Monochrome sales continued to decline, however, slipping 16 percent in June.

Projection television registered another strong performance in June, expanding 32 percent.

Consumer Electronics demand

Video and home computers are seen as the fastest-paced segments in the consumer electronics industry where technological innovations and new products will drive the total home electronic entertainment and information systems market to an overall 20 percent growth in 1984 to 1987, according to a new study.

Though the market is comprised of a number of mature products, says "Home Entertainment and Information Systems" (#1279), a new Frost & Sullivan report, innovative new products will enter the market, helping to stimulate consumer demand. Two examples of this are compact disc technology and stereo television. Also, dramatically declining prices are expected to spark the market for home computers.

1990 forecast: 50 percent of PCBs will use S-M technology

By 1990, it is forecast that 50 percent of all printed circuit boards will use *surface-mount technology*. Advances in design, assembly and test equipment coupled with the availability of a complete range of S-M devices have made board size reduction up to 70 percent and cost reduction of up to 50 percent a reality through the application of surface-mount-

ing techniques. To keep pace with S-M growth, it also is forecast that by 1990, 41 percent of the active and passive components used in equipment will be surface-mounted devices. Improved reliability, higher performance and lower cost needs are providing the backdrop to the acceleration of surface-mount technology application in new equipment design.

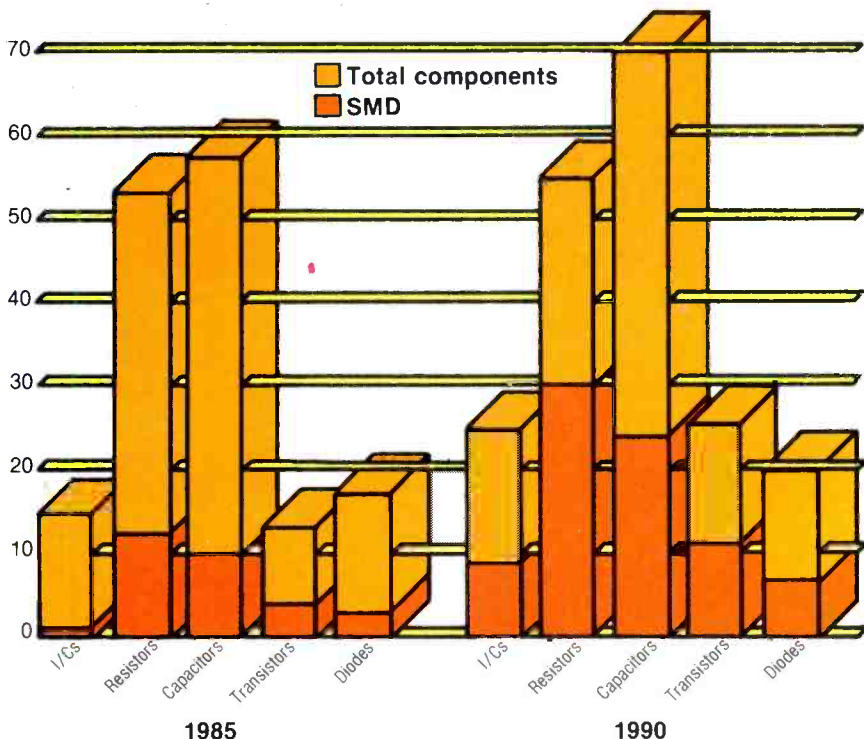

World surface mount device consumption (x 10⁹ units)

Test your electronic knowledge

By Sam Wilson

The subjects this month are *inductance* and *magnetism*. These are beginning-level questions so you should expect to get a very high score. Many technicians have trouble with questions that have a person's name (such as Faraday or Maxwell) in the answer. So, those questions may prevent you from scoring 100 percent on this easy test.

1. Which of the following has the least effect on coil inductance?

- A.) The shape of the coil.
- B.) The current through the coil.
- C.) The number of turns of wire.
- D.) An iron core vs. an air core.

2. Increasing the length of a coil without changing the number of turns will cause its inductance to

- A.) increase.
- B.) decrease.

3. If you raise the temperature of a material high enough, all of its magnetism will disappear. The name associated with that temperature is

- A.) Henry.
- B.) Gauss.
- C.) Curie.
- D.) Maxwell.

4. Magnetizing a piece of iron will change its

- A.) shape.
- B.) weight.
- C.) color.
- D.) dc resistance.

5. A certain coil is in a circuit where the frequency increases. *An increase in frequency always will increase the coil's opposition to current flow.* This statement

- A.) must be true.
- B.) cannot be true.

6. A certain coil has an air core. There is both ac and dc current in the coil wire. Which of the following statements is correct?

- A.) Increasing the dc current will increase core saturation and reduce inductance.
- B.) Increasing the dc current should not affect the inductance of the coil.
- C.) Increasing the dc current should increase the coil's inductance.

7. Two single-layer coils were wound for maximum inductance. They have the same coil forms, equal lengths, and, equal diam-

eters. However, coil A was wound with #18 wire, and, coil B was wound with #28 wire. Which of the following statements is correct?

- A.) They have equal inductance.
- B.) Coil A has a higher inductance.
- C.) Coil B has a higher inductance.

8. Is this statement correct? The hysteresis loss of a transformer is reduced by laminating the iron core.

- A.) The statement is correct.
- B.) The statement is not correct.

9. A magnet *attracts* iron and steel materials. *There are some materials that are repelled by a magnet.* This statement is

- A.) true.
- B.) false.

10. The relationship between the amount of current in a wire and the force on that wire exerted by a magnetic field is determined by

- A.) Faraday's law.
- B.) Maxwell's law.
- C.) Ampere's law.
- D.) Henry's law.

Answers are on page 53

Now electronics technicians can get into VCR Servicing quickly and easily

Learn professional VCR servicing at home or in your shop with exclusive videotaped demonstrations

Today, there are more than 10 million VCRs in use, with people standing in line to have them serviced. You can bring this profitable business into your shop with NRI professional training in VCR servicing. This top-level training supports the industry's claim that the best technicians today are those who service VCRs.

Integrated Three-Way Self-Teaching Program

In one integrated program, NRI gives you a study guide, 9 instructional units, 2 hours of video training tapes accompanied by a 32-page workbook that pulls it all together. At home or in your shop, you'll cover all the basic concepts of video recording, mechanical and electronic systems analyses, and the latest troubleshooting techniques. Your workbook and instructional units also contain an abundance of diagrams, data, and supplementary material that makes them valuable additions to your servicing library.

The "How-To" Videotape

Your NRI Action Videocassette uses every modern communications technique to make learning fast and easy. You'll enjoy expert lectures and see animation and video graphics that make every point crystal-clear. You'll follow the camera eye into the heart of the VCR as step-by-step servicing techniques are shown. Both electronic and mechanical troubleshooting are covered . . . including everything from complete replacement and adjustment of the recording heads to diagnosing micro-processor control faults.

Plus Training On All The New Video Systems

Although your course concentrates on VCRs covering Beta, VHS, and 3/4" U-Matic commercial VCRs, NRI also brings you up to speed in other key areas. You'll get training in capacitance and optical video disc players, projection TV, and video cameras. All are included to make you the complete video technician. There's even an optional final examination for NRI's VCR Professional Certificate.



Covers Beta *and* VHS
systems with actual
instruction on
videotape.

The Best Professional Training

This exclusive self-study course has been developed by the professionals at NRI. NRI has trained more television technicians than any other electronics school! In fact, NRI has consistently led the way in developing troubleshooting techniques for servicing virtually every piece of home entertainment equipment as it appears in the marketplace.

Satisfaction Guaranteed . . . 15-Day No-Risk Examination

Send today for the new NRI Self-Study Course in VCR Servicing for

Professionals. Examine it for 15 full days, look over the lessons, sample the videotape. If you're not fully satisfied that this is the kind of training you and your people need to get into the profitable VCR servicing business, return it for a prompt and full refund, including postage. Act now, and start adding new business to your business.

Special Introductory Offer

This complete VCR training course with two hour videotape is being offered for a limited time only, on orders received from this ad, at our low introductory price of \$179.95. Save \$20 by acting now!

NRI Training For Professionals
McGraw-Hill Continuing Education Center
3939 Wisconsin Avenue Washington, DC 20016

YES! Get me started in profitable VCR servicing. Rush me my NRI self-study course in VCR Servicing for Professionals. I understand I may return it for a full refund within 15 days if not completely satisfied.

PLEASE SPECIFY TAPE FORMAT DESIRED VHS BETA

Name (please print) _____

Company _____

Street _____

City/State/Zip _____

Enclosed is my check money order for \$179.95 (D.C. residents add 6% tax) Make check payable to NRI

Charge to VISA MasterCard _____

Interbank Number _____

Card Number _____ Expiration Date _____

Signature _____

(required for credit card sales)



NRI Training For Professionals
McGraw-Hill Continuing
Education Center
3939 Wisconsin Avenue
Washington, DC 20016

2631-095

Servicing videocassette recorders

By Neil R. Heller

The first article in this series presented the basic theory of videotape recorders. This second article will use this theory to cover practical adjustments and troubleshooting procedures.

Proper recorder performance depends on two factors: The videotape must make proper contact with the heads; the speed of the signal writing and reading must remain constant. This includes not only the speed of the tape transport that is determined by the capstan servo, but also the speed of the rotating video heads which is determined by the cylinder servo.

Troubleshooting a VCR involves drawing valid conclusions based on careful study of the facts. At all costs, avoid the urge to make quick assumptions. Often shotgun troubleshooting can result in creating problems that never existed in the first place. If you learn to read the VCR, in many cases it will let you know what is wrong.

Basic troubleshooting follows two simple practices: Start with the transport; finish with the electronics. Transport mechanical components such as rubber items and brakes, wear out and break down. Manufacturers usually recommend that these items be checked within the first 1000 hours of operation and replaced after 1500 hours.

Environmental conditions, such as smog, and extreme heat or cold, also can affect the operating life of these components. Problems caused by the lack of regular maintenance often result in poor or inconsistent recording. To the untrained technician, these problems can at first appear to be

caused by defective electronics. Be careful not to be fooled; always start with the mechanics.

Videotape transport

The tape transport system has two primary functions: first, to provide good tape-to-head contact and second to provide tape interchangeability. The former ensures good signal reproduction and the latter ensures that a recording made on one recorder can be properly played back on another. Transport problems may be such that no signal is recorded. This is dependent on head-tilt azimuth.

Playback signals come off the tape at extremely low levels. These amplitudes must be great enough to trigger the first stage of amplification. Misalignment of heads causes a 2-fold problem: During the recording process, signals are recorded at a lower-than-normal level; during playback these signals lose even more amplitude. The result is unacceptable playback.

Tape transport adjustments

All tape transports are manufactured to a standard that allows tapes recorded on one unit to be played back by another. In performing any type of repair or adjustment, it is extremely important that the repaired unit maintain interchangeability.

In order to assure that this condition is met, manufacturers provide service centers with a standard alignment tape. These tapes are recorded in Japan on special units that have tolerances which are monitored constantly. The signals recorded on tape are designed

to test all the important video, audio and servo parameters of the recorder. For this reason, a standard tape is more expensive than the typical pre-recorded tape.

Any time you use a standard tape, you should first check the recorder's physical transport condition by using an expendable tape, in case the recorder chews it up.

Tape transport alignment begins by checking the tape-to-head contact. This process is divided into two categories. The first is tape contact with the stationary heads such as the full erase, control track/audio head and the lower section of the video head cylinder. The second is contact between the tape and the rotating video heads. The latter type of adjustments need to be done whenever the video head is replaced.

The repair begins by removing the tape recorder case and any RF shielding that blocks a clear view of the tape transport. In some cases, this also includes removal of the cassette lid and/or the entire cassette housing, in order to adjust back tension properly or when the back tension adjuster itself needs replacement. Remember that these components are responsible for holding the videocassette in its proper position. When you load the cassette without the cassette lid or carriage, you have to use some external device to compensate for this loss of tension. Manufacturers' repair kits usually include some type of pressure bar.

After the cassette is loaded, use your eyes to confirm that the tape is being transported easily from the supply to the take-up reel. The tape should have good contact

with each of the guide posts. There should be no slack or creases in the tape caused by riding too high or low on the guide post. If an adjustment needs to be made, turn the guide post until the tape is positioned directly on the middle of the roller and is turning smoothly. Next observe the tape as it crosses each of the stationary heads. The tape should be parallel to each of the stationary heads. Each tape must cover the recording section of the head.

In the case of the VHS control track/audio head, (CTL/audio) the control track is recorded on the bottom section of the tape and the audio is recorded on the top section of the tape. The guide posts must position the tape so that it crosses both sections of each of the heads. Also, the tape must run parallel along the complete length of the individual head in order to maintain proper azimuth. Failure to do so will result in the lack of playback or recording of the signal.

Tape contact with the lower cylinder section is a little bit harder to eyeball for a rough adjustment. Start by looking for the tape guide edged into the lower cylinder section. The exit and entrance guide posts must be adjusted to meet two requirements. First, as previously noted, the tape transport must ride evenly on the guide posts. Second, the tape must be guided around the cylinder within the groove. This ensures that the video head will make contact with the tape for the complete period of time it takes to record one video field. At all costs, *do not* loosen the screw that holds the guide posts to the incline base. Its position is preset at the factory. Misadjustment will have a great effect on tape slack and the amount and quality of signal recorded on the tape.

Now is also a good time to check the back tension of the tape.

The back tension assembly consists of a felt band wrapped around the supply reel and a metal post that contacts the tape as it leaves the supply reel. As the tape moves from the supply to the take-up reel, the pressure against the post will change because of the transfer of bulk weight.

This change of pressure will cause the tension band to loosen or

tighten its hold around the supply reel. At the beginning of the tape when most of the weight is on the supply reel, the tension band will loosen. Toward the end of the tape, when the weight has been transferred to the take-up reel, the tension band will tighten. In this way, tape tension remains consistent with the shift of tape bulk. Without the use of a back tension band, the physical position of the tape would change with the tape load. This change would greatly affect tape-to-head contact thereby affecting signal quality.

The most common method of measuring back tension requires the use of a Tentelometer, manufactured by Tentel. Place the Tentelometer between the full erase head and the entrance guide post. Readings of 25 to 30 grams are common for VHS recorders.

Regardless of the type of recorder, the most important requirement is that the back tension remain constant for readings taken in the beginning, middle and end of tape.

If the back tension readings for these three sections of tape do not meet the manufacturer's requirements, adjustment or replacement of the back tension band might be needed. Only after the rough transport adjustments have been completed and, once again, you confirm the smooth transfer of tape between the supply and take-up reels, can you begin to fine tune the system.

The RF waveform

The key to the performance of any VCR is its capability to play back the recorded signal properly. Any deficiencies in the reproduction of the RF signal will result in a

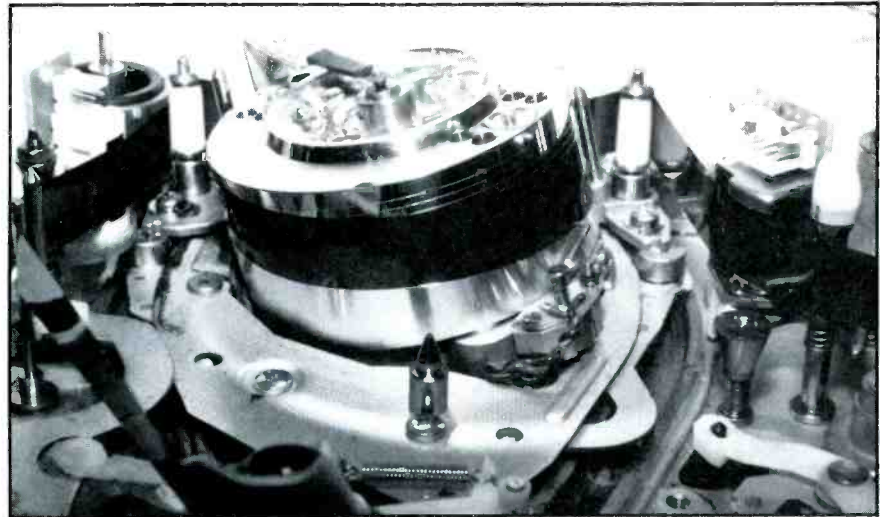

In a VCR, the tape is pulled out of the cassette and threaded tortuously through the transport system.

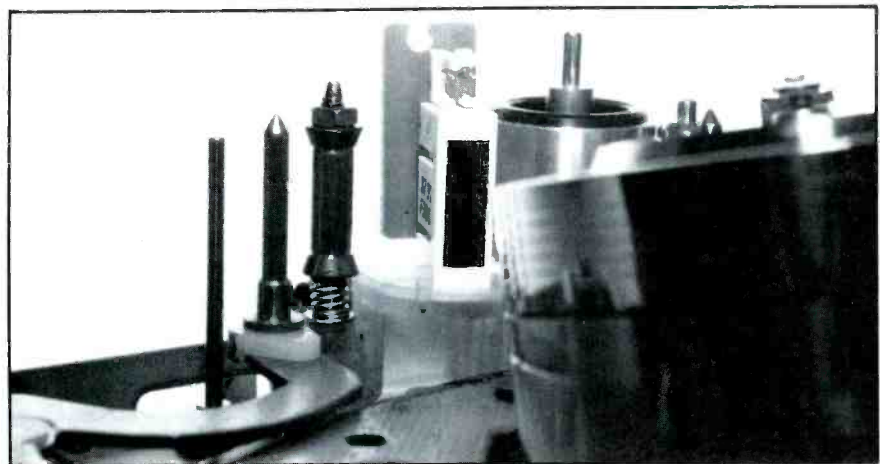

The first head the tape encounters on its trip through the transport system is the full erase head.

Servicing videocassette recorders

distorted playback picture. Assuming that the standard tape will provide properly recorded RF, then any distortion in the playback signal from the standard tape will be a result of mechanical or electronic problems within that individual unit. For this reason, the reading of the RF signal from a standard tape provides the key element to determining the source of problems in a faulty VCR. The playback RF waveform should be a close reproduction of the record current signal that is fed to the video head during the recording process.

As previously noted, the only major difference between the record current and the playback RF is the need to switch off the playback amplifier of the individual video head when it is not in contact with the tape. This leads to a small dip in the playback RF signal at the point where head switching occurs at field rate. The head-switching pulse taken from the servo circuit makes an excellent oscilloscope trigger pulse for observing the playback RF waveform. Also, because the head-switching pulse determines the turn *on* and *off* points for each of the head-playback amplifiers, it should not only be referenced to, but also displayed on the scope.

Set up your scope by inputting the head switching pulse into one of the scope channels and adjust it so that the changeover point falls on the center graticule of the scope. Use this channel as your trigger reference. Connect the other scope channel to the output of the video-head switching amplifier. Most manufacturers usually will provide test points for both the head-switching and RF signals. The output from each of the heads then will be displayed in each half of the scope faceplate. The RF waveform now can be read like a book. The left side of each

envelope represents the entrance point; the right side represents the exit point. The envelopes should each be of equal amplitude and distortion free. Normal output amplitudes usually are between 700mV and 900mV.

Amplitudes below 500mV are usually an indication that the head has worn down to the point where replacement is required.

Reading the RF envelope

In performing these checks and adjustments use the manufacturer's standard alignment tape. First confirm that both envelopes are free of fluctuations. If fluctuations are occurring, chances are you also are seeing noise bars run through the playback picture. This is usually an indication that a servo problem exists. Either the capstan or the head cylinder is running off speed so that the video heads are

crossing between the video tracks and the guard bands. As a result, the RF signal is decreasing and increasing, depending on whether it is reading the signal from the video track or the absence of signal from the guard bands. Use your eyes to confirm that the tape is making physical contact with the control track head. Further troubleshooting will require looking at the servo circuits, which will be covered later. For now, assume that the servo circuits are performing properly.

Distortions on the left side of the waveform will mean that the entrance guide post requires adjustment. Distortions on the right side mean that the exit guide posts require adjustment. If the individual envelope displays a dip in the middle, with raised points at both ends, it indicates that both the entrance and exit guide posts need

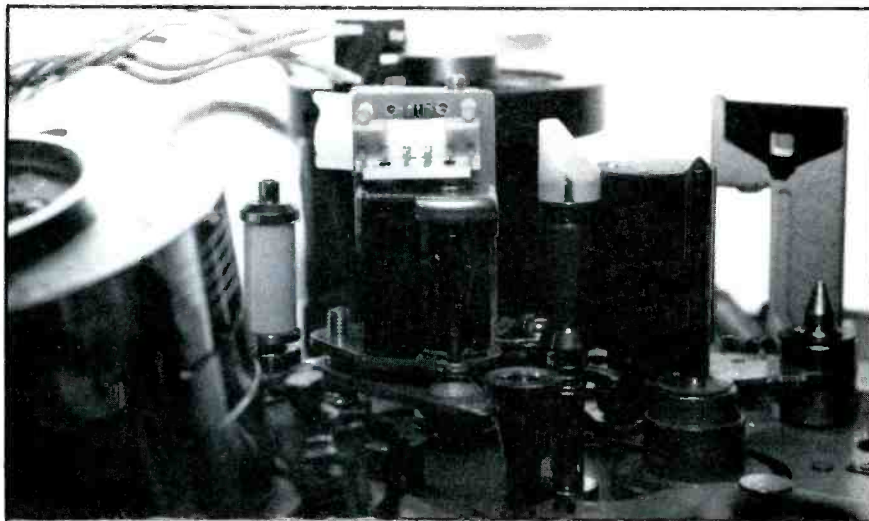

Proper adjustment of the tape transport system assures proper contact of the tape with the CTL/audio head, as shown here.



After the tape leaves the record/playback heads (upper cylinder) it encounters the CTL/audio head.

Exclusive Offer

for Microprocessor Based Equipment Servicing MANAGERS ...and key technical personnel

If you manage a facility which services computers, word processors, health care equipment or any other equipment which is microprocessor based, you can receive FREE a new magazine written exclusively with your management interests in mind.

Introducing...

M Microservice Management

With MSM, you receive in-depth, **useable** management information to help you run your business for maximum profit and efficiency. And updates on the newest equipment and technologies presented with a management perspective, to help you determine which products will work best for you and your technical staff.

Typical articles and topics covered in MSM include:

Business/Service Management
Marketing Strategy & Techniques
Personnel Management/Employee
Training

Pricing Strategy
Successful Business Case Studies
Technology Updates for Managers

New Products
New Literature
Association/Industry News

MSM is the **only** international magazine which directly serves **management** in the microprocessor based equipment servicing industry. And it's absolutely FREE to all **qualified** microserving facility managers and key technical personnel.

To receive your free subscription to Microservice Management, simply complete and return the coupon. We'll promptly mail you a subscription order form.

YES! Send my free subscription form for **Microservice Management**

Mail to: Jane Powell, Subscription Department
MSM
P.O. Box 12901, Overland Park, KS 66212

Name _____ Title _____
Company _____
Address _____
City _____ State _____ Zip _____
Equipment Serviced _____

Servicing videocassette recorders

adjusting. Distortions in the RF envelope not always are seen clearly with the recorder's tracking control set to maximum RF output. For this reason, detune the tracking control for minimum RF output. In most cases, readjustment of the guide posts probably will be necessary. Move the tracking control between maximum and minimum RF output and confirm that each of the head envelopes remains flat. Should each of the envelopes exhibit different output levels, it is an indication that further electronic or mechanical head positioning adjustments are required. This is usually the case if you have just replaced the video head.

Adjusting the CTL/audio head

Before fine tuning the position of the CTL/audio, reconfirm that the videotape is riding smoothly across both heads: the control head, located at the bottom of the tape and the audio head located at the top. The final positioning of the head will ensure that audio, control pulse and RF outputs are maximized.

Signal amplitude depends on proper contact of the head with the tape. RF output depends on horizontal positioning of the head. Because the control track pulse is responsible for maintaining correct capstan speed in the playback mode, the horizontal position of the head across the tape will determine the time frame when the signal is read. The control pulse is designed to allow the video head to read the center of the video track.

The actual horizontal position of the control track head will have little effect on the playback on a self-recorded tape; however, if the recorder is not accurately adjusted, replaying on another unit might prove difficult if not impossible, even with the use of the tracking control. The standard

tape has recorded control track pulses with the head set to its proper horizontal position. By playing the standard tape, maximum RF output only will be achieved with the head set to its correct horizontal position. Settings other than this position will send a message to the capstan servo to speed up or slow down. In either case, the video head will not be timed to read maximum video track output and the RF output will be lowered.

To fine adjust the position of the CTL/audio head, play the standard tape. Use the oscilloscope to observe the signal outputs of both the audio and CTL pulse. Adjust the azimuth and tilt of the head so that both outputs are maximized. You may find that this adjustment becomes a bit of a compromise as the maximum setting for one signal may not yield the best signal

output for the other. Next look at the RF output. Beginning with the tracking control set to the detent position, confirm that the RF signal drops when the tracking control is moved to either side. If the RF waveform increases when the tracking control is moved from the click position, move the head horizontally until maximum signal is achieved with the tracking control set in detent.

Adjusting the servos

The transport as a whole allows recordings on one unit to be played back on another unit. Any mechanical device is continuously subject to internal instabilities, known as time base errors. The electronic servos are designed to compensate for these variations so that the output picture will remain constant. Each of the four servos, cylinder phase, cylinder speed,

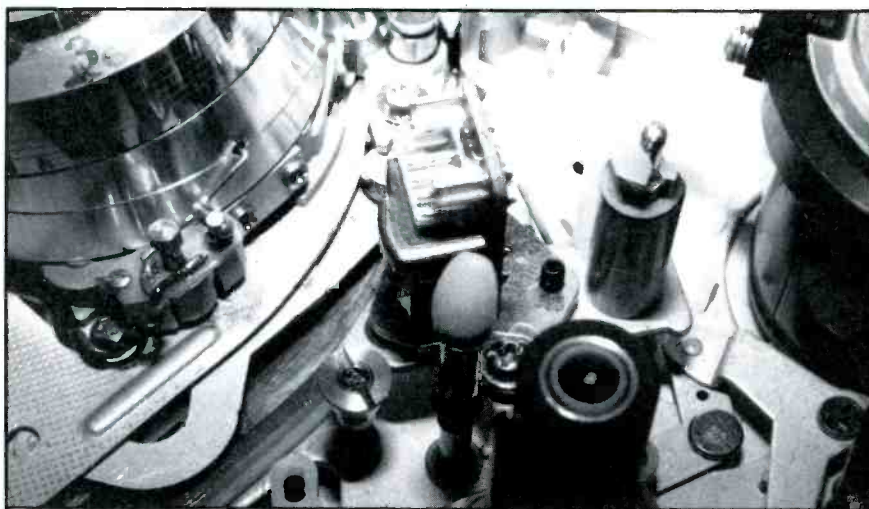

Adjustment of this screw positions the CTL/audio head.



Guide posts such as this help keep the tape in proper position.

HOW MUCH DO YOU KNOW ABOUT THIS RCA LV REG. CIRCUIT

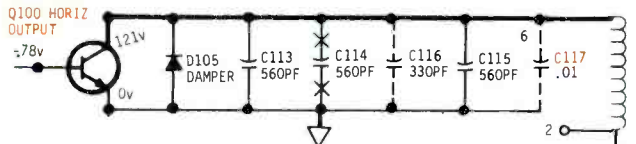

Typical of RCA CTC 85 thru 108 LV Regulator Circuits

Schematic by Diehl Engineering

How many of these questions can you answer ?

- (1) Every circuit has a beginning and an ending. Where does this circuit begin ?
- (2) Specifically, what is the purpose of this circuit ?
- (3) What turns it on ? What turns it off, or does it ever really turn off ?
- (4) Does this circuit have a shut down feature ? If so, which components are involved ?
- (5) What would happen if Q103 were to become shorted E to C ?
- (6) What purpose does Z115 serve ?
- (7) What would happen if D114 became shorted ?
- (8) What purpose does C126 serve ? What will happen if C126 becomes open ?
- (9) Is the winding between terminals 3 and 4 of the flyback a primary or a secondary winding ?
- (10) What purpose does C117 serve ? Exactly what does it do, and exactly how does it do it ?
- (11) Exactly what do resistors R113, 114, 115, 116, and 117 do ? What happens if they change value ?
- (12) What occurs that causes this circuit to produce an initial start up pulse ?
- (13) Why does this entire circuit become shorted and begin to destroy horiz output transistors if the regulator SCR becomes shorted ?
- (14) There is exactly one safe and practical method of circumventing this LV regulator circuit for test purposes. This technique does not involve a variac. Instead, you must disconnect one wire then connect a jumper wire from terminal #4 directly to _____ Which wire do you disconnect and where do you connect the other end of your jumper wire ?
- (15) If SCR100 is shorted, this circuit will still "eat" horiz output transistors even if you are using a variac. Why ?
- (16) Why does this circuit use a floating ground ?

We publish a monthly magazine called the Technician / Shop Owners Newsletter. Each month we take a popular circuit and absolutely dissect it.

Using color coded pictorial schematics such as the one above, we "map out" every action in the overall sequence of events that must take place during each and every cycle.

Beginning with the very first "action" in the sequence (which just happens to be depicted in the above schematic) we explain exactly what is taking place. We then explain the function of every component in that portion of the circuit. After explaining the function of each component, we show you how to troubleshoot that particular "action" or function.

After reading our newsletter on this circuit, you could answer all of the above questions as fast as anyone could ask them. In fact, you will then know everything there is to know about this circuit. Including how to troubleshoot it !!

Regardless of whether you work on TV sets, stereos, radios or computers, just having the ability to "dissect" an electronic circuit (any circuit) is worth a fortune. In reality, "dissecting" is exactly what our newsletter is designed to teach you.

Because of the manner in which our newsletter is written, the subject matter that is gained from each monthly issue is so extremely broad that it will "spill over" into your everyday troubleshooting routine, and be applied to totally unrelated circuits.

This entire training program sells for only 119⁴⁰ per year (12 separate issues). Virtually every one of our subscribers agree that no other publication is as informative. By using the attached order card you can purchase the first three of fifteen issues for only \$29⁸⁵. Just these three issues alone will vastly improve your knowledge of electronics.

For immediate service call your order into us at (806) 359-0329 or (806) 359-1824.

Diehl Publications, 6661 Canyon Drive Bldg. E, Amarillo, Texas 79110

Servicing videocassette recorders

capstan phase and capstan speed, must be adjusted to provide both the maximum RF output and the *fastest recovering* time to mechanical variations.

Troubleshooting the servo system

At a first look, all servo problems exhibit the same problem: noise running through the picture.

Troubleshooting the servo system is a matter of isolating the problem to one of the four systems. First determine if the condition exists in the playback or record mode. Simply play back a known, good tape. If the recorder will play a prerecorded tape, but will not play a self-recording, then the problem is probably in the record mode. Next determine whether the problem exists in the capstan or cylinder servo. This is a simple matter for any recorder that has a still mode. Play back the standard tape or any tape of known, good quality and place the unit in still mode.

If the unit reproduces a good still, it is a fairly good indication that the cylinder servo is working properly. Variations in the cylinder servo will change the sync fre-

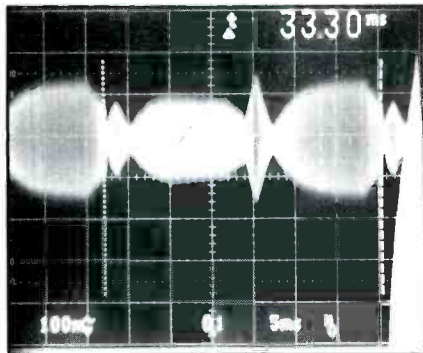

An oscilloscope trace of the RF waveform from a manufacturer's standard tape provides valuable information about tape transport condition. In this case, distortion on the left side of the waveform reveals that the entrance guidepost needs adjustment.

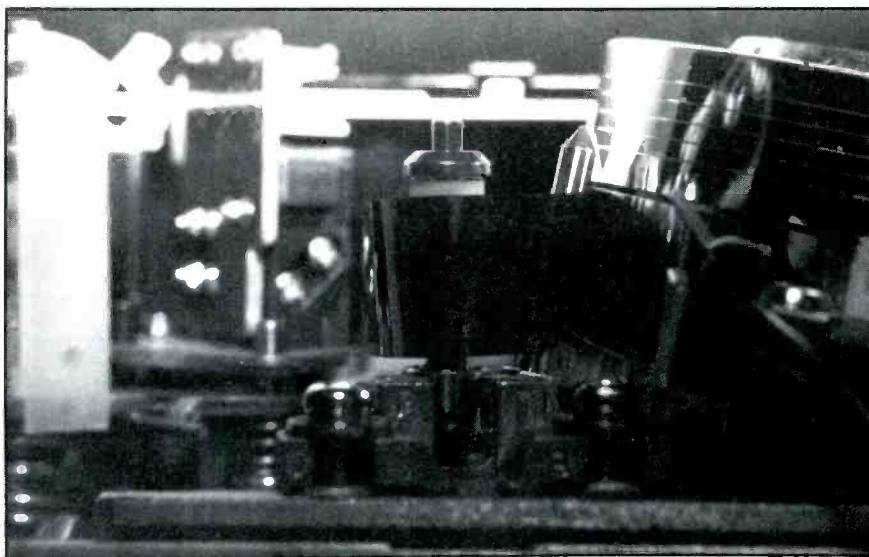

Here, tape is shown riding too low on guide post. Such a situation could cause poor recording/playback or damage to the tape.



Back tension may be adjusted using a Tentelometer. Tension should be in the range of 30 ± 5 grams.

quency of the output video. Regardless of whether the cylinder is turning too fast or too slow, the monitor will not be able to lock on the horizontal frequency.

The condition will look like someone has turned the horizontal control of the television set. After the mode and type of servo has been determined, use the oscilloscope to look at the sample and hold. Work backwards through the phase servo to the variable or fixed reference points or forward to the speed servo.

Summing it up

Adjusting or repairing the videotape recorder is usually a matter of following a set of established procedures. Start with the transport, end with the electronics. Me-

chanical components wear and fail more often than electronic components. Begin with the rough adjustments and use the scope to fine tune. Never use electronic adjustments to compensate for mechanical problems. Finally, remember that the overall goal is to record and reproduce, as perfectly as possible, the RF waveform.

The third part of this series will cover the most common types of VCR repair: video head and transport component replacement. It will discuss when and how to replace the video head, how to adjust the video head by setting protrusion and height, and additional information about interpreting the RF waveform in order to perform these adjustments.

ES&T

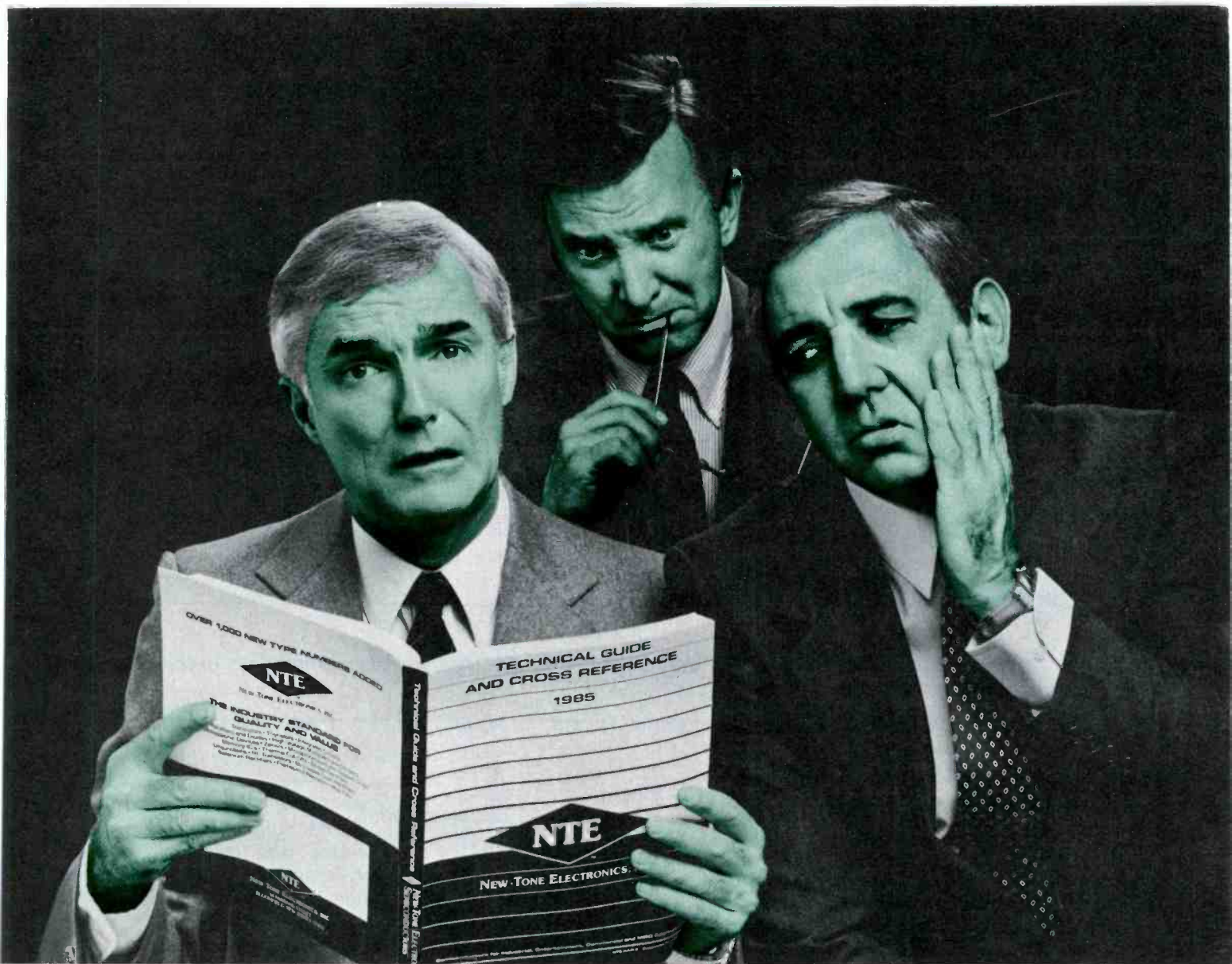

WE'RE TURNING THE COMPETITION GREEN WITH ENVY.

NTE is the red hot success story of the electronics industry and the big boys are green with envy.

They don't like the fact that we've built our reputation on giving you more of what you're looking for in a replacement part. More quality. More reliability. And, more parts to choose from. That's why more and more technicians across the country are picking the package with the green NTE diamond on the front.

NTE parts are extensively tested on state-of-the-art equipment during every phase of production to ensure top performance — performance that's backed by the industry's only two year warranty.

What's more, NTE uses a special computer controlled inventory system, so when you replace or design with NTE, you can be sure that the part you need is on your distributor's shelf. Our new 1985/86 Technical Guide and Cross-Reference manual, which has over 3,100 NTE types cross-referenced to over 220,000 industry part numbers, is now available.

Why settle for our competitor's parts when you get more quality and service with NTE? Look for NTE's replacement parts in the bright green polybags and cartons at your distributor today.

Don't forget to ask about our new Flameproof Resistors and Wire Ties, too!



NTE ELECTRONICS, INC.

44 FARRAND STREET, BLOOMFIELD, NEW JERSEY 07003

Circle (8) on Reply Card

www.americanradiohistory.com

Diagnosing VCR head problems

Question:

How do video heads resemble the engine of that automobile parked in your driveway?

Answer:

They both are taken for granted; they both are expensive to replace when they break down.

Similarities between VCRs and cars include brakes, clutches, motors, solenoids and electromechanical devices that simply wear out after hours of use. In the next few years, we're sure to see a proliferation of VCRs mechanically *wearing out* because the number of home video recorders in the United States is passing the 20-million mark in 1985 and growing at 10-plus million units per year. And because most video technicians sharpened their talents while repairing TV sets, it is the mechanical breakdowns that will cause the majority of headaches.

Video heads are about the most expensive mechanical component to replace in a VCR, and we know they *all* will need replacing after some number of hours. This article deals with various methods of detecting VCR head problems.

Bad heads, big headaches

Detecting a *bad* head is a relatively simple procedure—or is it? It is easy to see the result of a bad head, but it is not so easy to determine the actual cause of the problem. At any one time in a VCR, there are two video head tips in use. One head scans the tape, and as it exits the edge of the recorded

video information, the control track pulse *tells* the circuitry to switch to the other (second) head tip because it is just entering the recorded zone. The heads continue switching *on* and *off*, controlled by the control track pulses, thus providing a continuous video signal. Actually, the picture is being put on the screen at the rate of 30 frames per second, but our eyes see a *continuous* signal.

Replacement needed or snow job?

It is extremely unlikely that both head tips (typically ferrite) will wear out at the same time. If you haven't seen video with one head not working, the effect is very distinctive. The video picture is a combination of a bad image and lots of "snow." (See top, page 24.) If you want to simulate the effect just to see what it looks like, merely unsolder one head wire from the drum connections on a VCR. Play a prerecorded tape and file this snowy picture in your memory bank; if you're repairing VCRs, I'll

guarantee you'll see it again.

If you replace every head you encounter that has this symptom, you're sure to be throwing away some good heads. If you did the snowy picture test, you've already seen that a broken head wire will cause the same effect as a worn head. The most common cause of the snowy picture is a *head clog*. A head can become clogged by some tape oxide bridging across the microscopic gap of the head. This clog may be impossible to dislodge merely by using a cleaning tape. It may be necessary to *carefully* hand clean the head tip to dislodge the tenacious clog. The snowy picture might be an electronic problem in the pre-amp section that the head signals feed into. How can you correctly diagnose the problem? Here's a list of a number of possible problems that would cause a snowy picture. (See Figure 1.) There are at least five different methods of diagnosing video head problems. (See Figure 2.)

By guess and by gosh

The educated finger or guess method approaches an art. Video engineers with years of experience, after hundreds or even thousands of machines, can become some-

by Wayne B. Graham



When one VCR video head is not working, the very distinctive effect is a combination of a bad image and lots of snow.

what proficient at feeling the head tips to determine the condition. Some may even be able to hear the audible whine of the heads against the tape and provide useful guesses regarding the condition of the head tips. This method for most technicians is doomed to failure. And each time you misdiagnose a head problem, you'll either be replacing a good head, or you'll fail to replace a head that is about to fail.

Many of the older VCRs were *basic* models by today's standards, and it is possible to replace them, feature for feature, at a low cost with new equipment. With the large numbers of low-end (low-cost) VCRs you may not be able to replace a head on a guess, because the cost to do so, with a few other adjustments, may approach the cost of a new low-end VCR. If you repair a VCR but the heads are nearly worn, you'll simply have to do the job again when the head fails in several days or weeks.

Developing an educated eye

The microscope is a step up from the educated finger, but now you must develop an educated eye. The entire range between a new and a worn VHS (or Beta) head is less

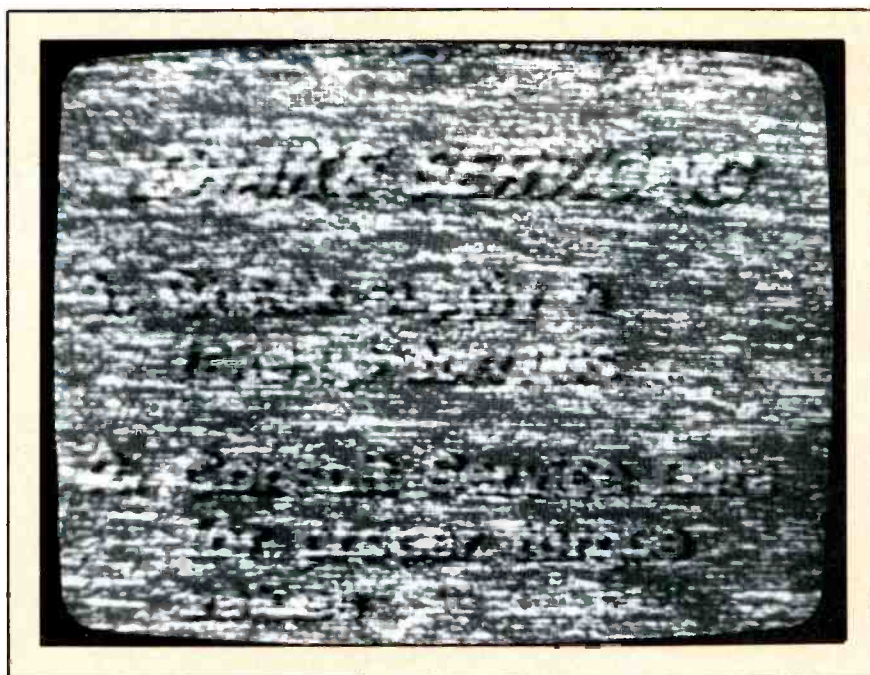

than 0.0015 inch, (typically closer to 0.001 inch), so it's difficult to reach a quantitative number to determine the condition of the heads. It is a fair method of determining if the head tips are in new condition or really worn, but it's difficult to make a determination between these extremes. A visual check with a microscope also is an excellent method of determining if there is hair, fuzz or similar foreign material caught on the head tips, preventing proper head-on-tape contact. On page 26, top, is a picture of a VHS video head

drum and tip. Below, is shown a magnified view of two VHS head tips. The tip on the left is new (0.0019-inch protrusion) and the tip on the right is worn (0.0005-inch protrusion). These heads were removed from the machine to allow a clearer picture to be taken. The line in the center is 0.002-inch thick, to enable you to *calibrate* your eye to visible wear.

The electronic approach

Electronic substitution provides a method of determining whether the problem is in the head tips or in the electronics. A signal, simulating the head, is fed into the pre-amplifier section. If the signal is processed properly by the VCR electronics (viewing video out), then it can be determined that the problem is with the video head tips or connecting head wires. Unfortunately, this method will not detect a clogged head or a small piece of hair or fuzz that may be caught on the head, preventing head-to-tape contact. This also may result in replacing a good head, or com-

1.) Normally worn head

2.) Head clog

3.) Broken head wire

4.) Electronic problem

5.) Other

Figure 1.

1.) Educated finger or guess

2.) Microscope

3.) Electronic head signal substitution

4.) Inductance head checker

5.) Mechanical head protrusion gauge

Figure 2.

Figure 1. A snowy picture from a VCR may be caused by one of these problems

Figure 2. Here are five methods of diagnosing video head problems.

pleting a repair and leaving an almost worn head, because this method can't be used for determining the remaining life of the video heads. It's a gamble.

Measuring inductance

Measuring the inductance of the individual head tips is a good method of determining their condition. It is quite important that each pair of heads be of matching inductance, otherwise tuning the pre-amp will become virtually impossible. Each model of the various manufacturers' heads has its own, distinct range of acceptable inductance values.

The booklet that comes with the *head checker* lists some head-part numbers and their respective readings, however we were unable to find listings for many of the newer heads. Beta HiFi and VHS HiFi are introducing entirely new sets of heads; usually with six different head tips. It would be necessary to obtain inductance specifications for each of the three pairs of scanning head tips. (Testing also would require that the leads to these six heads be unsoldered.) Problems with any one of these six tips will cause the machine to need repair.

Head protrusion, eccentricity vs. new VCR

Mechanical determination of head protrusion (tip projection) is an excellent method of providing a quantitative measurement of the actual head life of the VCR. Back in the days of quad, professional broadcast 2-inch tape, head protrusion was a necessary measurement for proper setup. High quality control levels by the Japanese on the 3/4-inch U-matic and, then, Beta and VHS greatly reduced the need for head protrusion measurements. When there was a problem, a new head was installed. With new VCR prices so low and with the millions of VCRs currently in use, it now is difficult merely to replace the video head as a troubleshooting technique.

To measure head protrusion, the top cover is removed from the VCR, and a special measuring probe is placed into contact with

EIGHT HIGH-TECH SOLUTIONS FROM PHILIPS ECG.



New high-purity chemicals for your high-tech repairs.

Circuit refrigerants, flux removers, restorers and cleaners. They're going to extend the life and improve the performance of your electronic components and electronic repairs.

Today, no matter what your repair job, no matter how large or small, a world leader in electronics has your solution. High-tech chemicals from Philips ECG.

High-tech chemicals are available from your Philips ECG distributor. For the name of the distributor nearest you, call 1-800-225-8326.

PhilipsECG

A North American Philips Company
Dedicated to Excellence.

Circle (9) on Reply Card

September 1985 *Electronic Servicing & Technology* 25

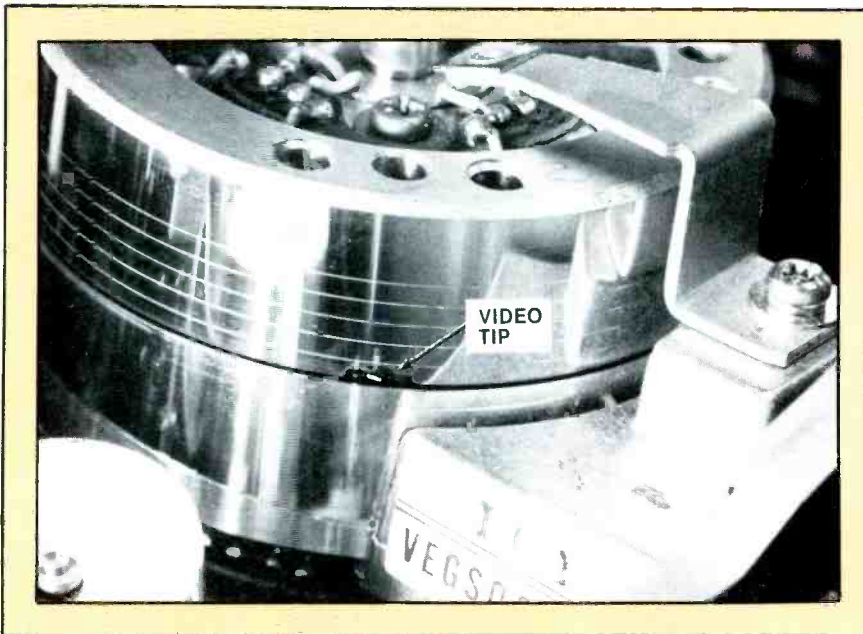

A close-up view of the head drum looks like this.

This magnified view of two VHS video head tips contrasts a new tip of 0.0019-inch protrusion, on the left, with a worn tip of 0.0005-inch protrusion. The 0.002-inch-thick line in the center of the photo is there to give you an idea of dimensions.

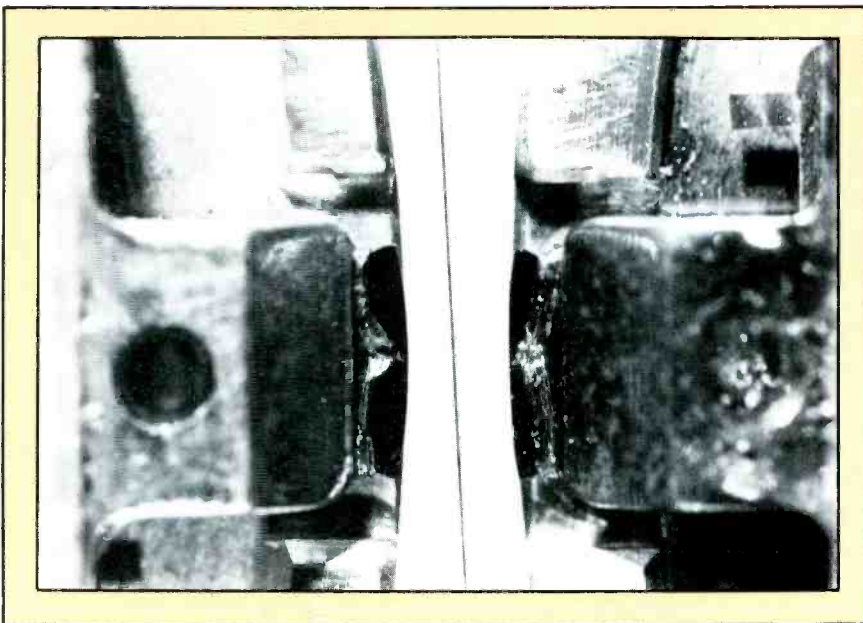

the video drum. As the video head is rotated slowly by hand, the protrusion of each video head tip is determined. This method works for all types of head tips and provides good quantitative readings of remaining head life. Figure 3 shows readings in both ten-thousandths of an inch and in microns for heads in various stages of wear. If the snowy picture problem is detected but the protrusion method shows adequate head tip remaining, it would be advisable to go through the possible problems listed in Figure 1 (2-5).

Don't confuse head protrusion with drum eccentricity. Eccentricity gauges are commonly available for measuring the amount of drum run-out or *off centeredness* of a video head drum, to allow the drum to be centered during replacement. These were a necessity on the U-Matic and early Beta type machines but VHS heads usually are self centering (make certain all locating surfaces are clean and lint free). The specifica-

Continued on page 61

Figure 3. This grid shows typical dimensions for head in various stages of wear.

Head Protrusion				
Readings shown in inches (microns)				
	Lowest (could go anytime)	Lowest Good (marginal)	Typical (good)	Highest Good (probably new)
U-Matic	.0009 (23)	.0013 (33)	.002 (51)	.003 (76)
VHS	.0004 (10)	.0007 (18)	.0015 (38)	.0020 (51)
BETA	.0004 (10)	.0007 (18)	.0012 (30.5)	.0020 (51)

Figure 3.

How Many Times Do You Intend To Let "THE SAME DOG" Bite You ?

★ How many times have you worked all day long trying to diagnose the hi-voltage / LV regulator circuit of a set that is in shut down only to eventually find that a **shorted** video, color, vertical, tuner, AGC, or matrix circuit was causing the set to shut down and, to find that the hi-voltage / LV regulator circuit was working flawlessly all the time?

★ How many times have you spent the day looking for a **short** that was causing the set to shut down, only to eventually find that an **open** vertical, video, matrix circuit or, an **open** HV multiplier was to blame?

★ How many times have you worked all day on the same TV set, only to find out that the set's flyback transformer was defective?

★ How many flyback transformers have you replaced only to find that the original flyback was **not** defective?

★ How many horiz output transistors and Sony SG 613 **SCRs** have you destroyed while simply trying to figure out whether the flyback was good or bad?

★ How many times have you been deceived by your flyback "ringer"? Can you even count the number of hours that your "ringer" has caused you to waste?

★ How many times have you condemned a flyback, only to find that a shorted scan derived B+ source was causing the flyback to "appear" as though it were defective?

★ How many hours have you wasted, working on a TV set, only to find that the CRT had a dynamically shorted 2nd anode (to primary element)?

★ How many new sweep transformers have you unknowingly destroyed because a short existed in one of the scan derived B+ sources?

★ How many times have you said to yourself, "I could fix this --- thing if I could only get it to fire up long enough to lite the screen? --- without blowing an output transistor or a fuse."

★ How many additional bench jobs could you have gotten, had you been able to give an accurate, "on the spot" estimate on sets that were either in shut down or, not capable of coming on long enough for you to analyze them?

If you had been using our all new Super Tech HV circuit scanner, you would have had an accurate evaluation concerning all of the above in about one minute, at the push of **just one** single button.

It's true! Push just one test button and our HV circuit scanner will (1) Accurately prove or disprove the flyback, (2) Check for any possible shorts in any circuit that utilizes scan derived B+, (3) Check the scan derived power supplies themselves for shorted diodes and / or electrolytic capacitors, (4) Check for primary B+ collector voltage and, (5) Check the horiz output stage for defects.

Our HV circuit scanner works equally well on sets with integrated or outboard HV multipliers. It will diagnose any brand, any age, solid state TV set including Sony. The only exceptions are sets which use an SCR for trace and, another for retrace (i.e., RCA CTC 40 etc.). Our scanner will not work on these sets.

In plain English, our HV circuit scanner is even easier to operate than a "plain vanilla" voltmeter.

First off, when you're using a scanner, you **do not** remove the flyback in order to check it. In fact, you don't even unhook any of the wires that are connected to the flyback! All you do is:

(1) Remove the set's horiz output device, plug in the scanner's interface plug, then make one single ground connection. That's all you do to hook it up.

(2) If the primary LV supply is functional and, assuming that the emitter circuit of the horiz output stage has continuity, the scanner will tell you that it is ready to "scan" by illuminating the "ready" light, which is the white button on the test / run switch.

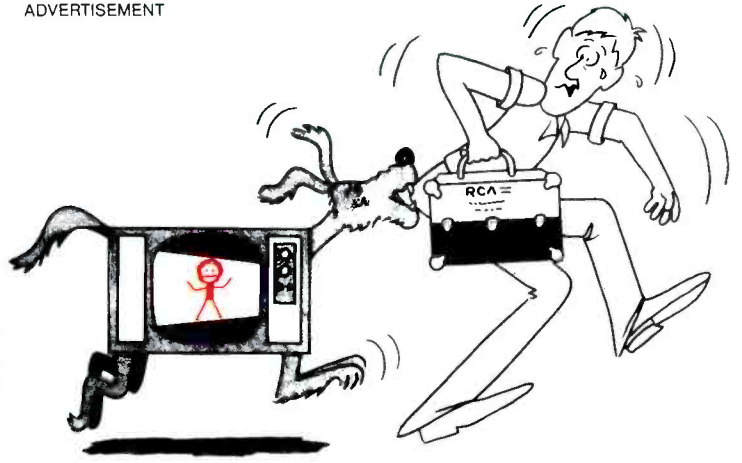

(3) Press the spring loaded (test) side of the test / run switch and the scanner will "look" for any type of a **short** that might exist anywhere on the secondary side of the flyback, including the HV multiplier, any circuit that relies on flyback generated B+ and, including the flyback itself (both primary and all secondary windings). It will simultaneously check for a shorted LV regulator device HV multiplier, or an open or "partially" open safety capacitor.

If a short or, an "excessive load" exists on one secondary winding, all other secondary windings will have "normal" output voltage in spite of the short. Only the shorted winding itself will have zero volts on it. This makes shorted scan derived B+ sources incredibly easy to isolate. During this test, the 2nd anode voltage is being limited to approx 5 kv by the scanner.

If a short is present, the red "flyback" light will either lite, or flash (at various speeds), depending on which type of a short exists. If no shorts exist, the "flyback" light will be green.

Assuming that the "flyback" light is green, no **shorts** exist and, it is now time (and safe), to begin looking for **open** circuits which might be causing the set to shut down due to flyback run-a-way. It only stands to reason that if no shorted conditions exist, then one (or more) circuits will have to be open, otherwise, the TV set would be working!

(4) Now that you know that no **shorts** exists, push the "run" side of the test / run switch (the side that latches). Provided all of the other circuits in the TV set are functional, the scanner will now put a picture on the set's CRT screen that has full vertical and horiz deflection, normal audio, video and color.

Keep in mind that during this test, your scanner is:

- (1) Circumventing all horiz osc/driver related shut down circuits,
- (2) Limiting the set's 2nd anode voltage to approx 20-25 kv,
- (3) Substituting the set's horiz osc/driver circuit and, as a result, eliminating any need that the set might have for an initial start up or B+ resupply circuit for the osc/driver.

Wait about 15 seconds for its filaments to warm up, then look at the CRT. Any circuits that are "**open**" will now produce an obvious symptom on the screen. Because the scanner has circumvented all of the set's shut down features, you can now use your old reliable "symptom to circuit analysis" technique to troubleshoot the problem, i.e., if the picture has no blue in it --- repair the blue video or blue matrix circuit. If the picture has only partial vertical deflection --- repair the vertical circuit, and so on. The scanner has effectively removed all of the stumbling blocks that would normally prevent you from diagnosing the problem. i.e., start up and shut down features, and allowed you to repair the TV set by using conventional techniques.

When you're using a scanner, all start up, shut down, dead set problems are easy to solve. You don't need anyone to tell you just how difficult these problems can be for those who don't have a scanner!!

Our Super Tech HV circuit scanner normally sells for only \$495⁰⁰. Beginning July 4, 1985 thru August 31, they are on sale for only \$395⁰⁰.

VISA, MASTERCARGE, C.O.D. ORDERS WELCOME

DIEHL ENGINEERING • 6004 Estacado Ln. • Amarillo, TX 79109

PHONE (806) 359-1824 or (806) 359-0329

Phone Orders Welcome

Since the Scanner only has two buttons to press, most technicians never need it but, our "Hot Line" is available to assist new owners in the operation of their scanner. Phone (806) 359-0320.

Circle (10) on Reply Card

What do you know about electronics?

Blowing misconceptions about fuses.

by Sam Wilson

In the March 1985 issue, I made the following statement about fuses, "The voltage rating does not have anything to do with arcover after the fuse has opened."

I received a number of letters asking for an explanation. The idea I want to convey is that a rating of 250V does *not* mean that there won't be any voltage problem as long as the blown fuse is in a circuit which doesn't exceed 250V.

I'll come back to that point after a short discussion of fuse theory.

Fuses are rated by the current they can pass safely. This gives the wrong idea that excessive current will cause a fuse to blow. *There is no amount of current in the world that can cause a fuse to blow.*

It is *power dissipation* that causes a fuse to blow. Specifically, it is power dissipation in the form of heat. To put it another way, it is the I^2R loss that causes the fuse to melt.

We tend to overlook that point for two reasons. First, the fuse is rated by *current*. Second, when we test a fuse with an ohmmeter, we look for a 0Ω display. But, the ohmmeter is being used for a continuity check—not a measurement.

If the fuse really had a resistance of 0Ω , it wouldn't blow if you passed all of the current out of Hoover Dam through it. That is an important point because the resistance of a fuse can be a significant factor in the design of low-voltage circuits.

Having pointed that out, I will now defer to statements made by the capable people at the Littlefuse Company. I'm sure you recognize that trade name. The following statements are direct quotations from their catalog.

"Short circuit rating: Also known as breaking capacity or interrupting capacity, it is the maximum current that the fuse can safely interrupt at rated voltage." When they say *safely interrupt*, they mean no explosion, no fire and no spray of molten solder.

"The voltage rating, as marked on a fuse, indicates the fuse can be relied upon to safely interrupt its short circuit current, in a circuit where the voltage is equal to, or less than its rated voltage."

Note that the *voltage rating* is not a specification that talks about safety in the circuit *after* the fuse is blown, as some people think. It is a rating that deals with the safe *interruption* of the circuit.

Think about this important point: The instant the fuse opens, all of the circuit voltage will be across that fuse. If there is going to be an arcover, it will occur at that instant—not at some later time. The fuse must open quickly so there is no sustained arcover and damage to the equipment. (As I will discuss later, I will point out that there can be an exception to this under certain conditions.)

Obviously, if the fuse will open at the instant it blows so that no arcover occurs, then it stands to reason that the fuse will automatically be safe in a circuit with that amount of voltage. But, this is after the fact.

In other words, if the fuse opened to the point where arcover could not be sustained, it is not about to arcover at that same voltage later. Listen to what the experts say:

"...a fuse may be used at any voltage less than its voltage rating without detriment to its fusing characteristics, but may also be

used at voltages higher than its certified voltage rating if the maximum power level available at the fuse under a *dead short* condition can only produce a low-energy level, non-destructive arc."

Under certain conditions, an arc can occur in a fuse after it is blown. The reason is that the fuse may be used in a circuit with a higher voltage than its voltage rating. The condition is that the arc is non-destructive.

Use your experience

Having read this, think back in your own experience. Have you ever had a problem with a fuse arcing over after it was blown? There is little chance that you have.

There is a chance, however, that the fuse holder can be a problem. I did run across an example where the fuse was not blown but the fuse holder caused some trouble. That's rare, but it can happen.

This will blow your fuse

I would like to give one more quote from the Littlefuse catalog.

"Fuses listed in accordance with UL Standard 198G are required to have an interrupting rating of 10,000 amperes..."

That is a let-through current. It means that a current of 10,000 amplifiers could sneak through before the fuse opens. (That does NOT mean there always will be a current of 10kA.) The power supply may not be up to providing that much current.

The short duration of the high current would prevent any serious damage to components. If you need extra-fast protection, you will have to supplement the fuse action with a crowbar or some other type of protection.

Some ideas about noise

Not long ago, when I was *very* young, a TV technician convinced me that the snow on the TV screen was picked up by the signal between the station and the receiver.

I've never mentioned this before, but a lot of the ideas for my articles come from the early days that I spent straightening out my head from ideas that were put in there by "experts."

Noise is any undesired signal. In a transmitter-receiver system, noise can be divided into two categories: noise generated *outside* the transmitter and receiver, and noise generated *inside* those systems. This article deals with some types of noise generated inside a system. We're talking about any system, not just transmitters and receivers.

Figure 1 shows the three types of noise that are characteristic of all amplifying devices. The broken line shows the way this curve usually is presented.

At the low-frequency end, the noise is inversely proportional to the frequency. This can be written as

$$\text{NOISE} \propto 1/f$$

So, it is called $1/f$ noise. In amplifying devices, this type of noise is due mostly to the flicker noise. This is caused by the surface effects of the cathode, emitter or source.

The white noise is misnamed. It is called that because it has a very broad bandwidth. Supposedly, that makes it similar to white light.

The problem with that is that white light, as we see it, is not composed of identical amplitudes of all frequencies.

For example, *illuminant C*, or the *Y signal*, represents white in a TV picture. In order to make it look white they have to use 11 percent blue, 30 percent red and green for the rest.

True white noise, however, has the same amplitude throughout the spectrum. White noise in an amplifying device is due primarily to shot noise. It is caused by the fact that the charge carriers don't all move together like nice little soldiers. Specifically, they don't always leave the cathode (or emitter, or source) at the same rate.

Likewise, they don't all arrive at the place where they are going at the same time.

The slight change in the number of charge carriers leaving where they come from and arriving where they're going means that there are small current or voltage variations that represent the noise signal.

If you want to be a name drop-

per, remember that white noise due to random motion of charge carriers in a semiconductor material also is called Johnson noise.

High-frequency noise in an amplifier is due partly to the fact that its input resistance is not constant. In most cases, the rise in noise above a few megahertz is rapid.

. . . Over 3,000,000 Sold and Still The Best General Purpose Multimeter! . . .



The Reason Is Clear . . .

Simpson 260[®] VOM

Has Features No Digital Can Match!



Latest 260[®] Series 7 \$119

- **"Instant"** null, peak, trend and continuity indications
- **High immunity** to transients, RF interference
- **dB measurement** capability at no extra cost
- **Resistance indication** from zero to infinity
- **Self-powered** voltage, current and dB ranges—no batteries to fail
- **Reliable, accurate performance** even under extreme environments
- **Easy, low-cost maintenance**—no expensive "chips" to fail
- **UL Listed** per UL-1244 Standard for Safety—Electrical and Electronic Measuring and Testing Instruments
- **Complete line** of UL recognized accessories
- **Options** include mirrored scale, extra overload protections, roll top carrying case

See the World Famous 260 Series 7, the 260-6XL, the 270 and the Pocket-Size 160[®] at Leading Electronics/Electrical Distributors



SIMPSON ELECTRIC COMPANY

A Katy Industries Subsidiary
853 Dundee Avenue, Elgin, IL 60120
(312) 697-2260 • Telex 72-2416 • Cable SIMELCO
Canada: Bach-Simpson Ltd., London, Ontario
England: Bach-Simpson (U.K.) Ltd., Wadebridge, Cornwall

Circle (11) on Reply Card

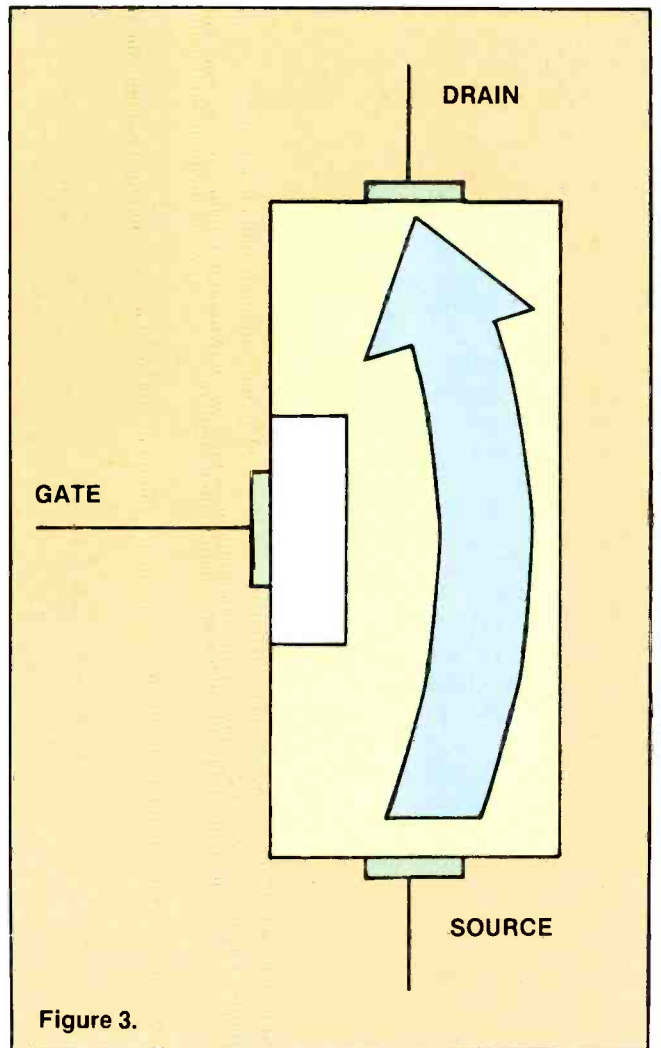
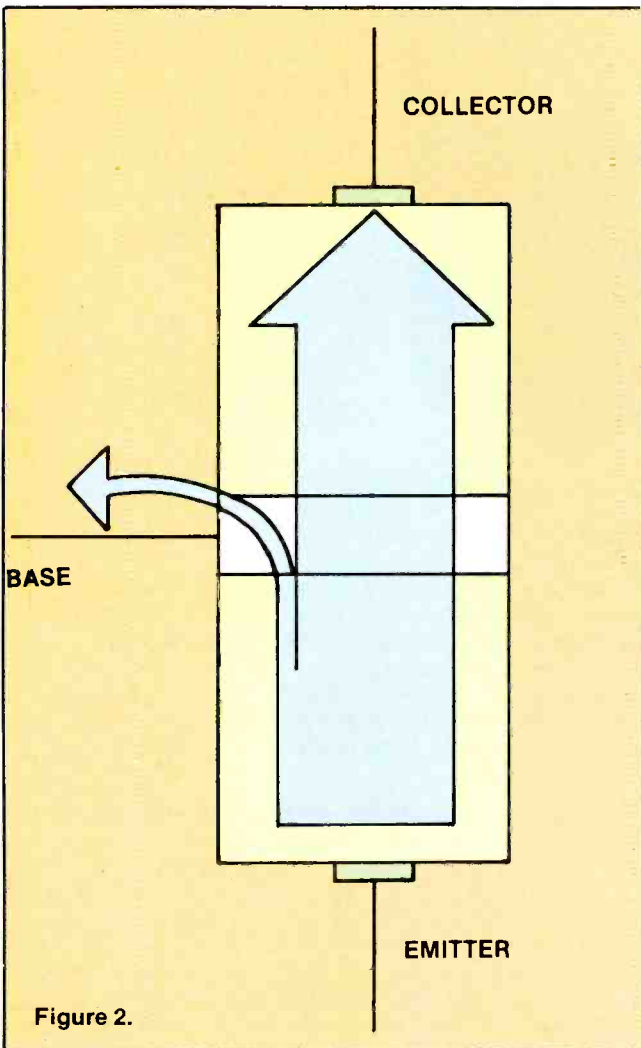
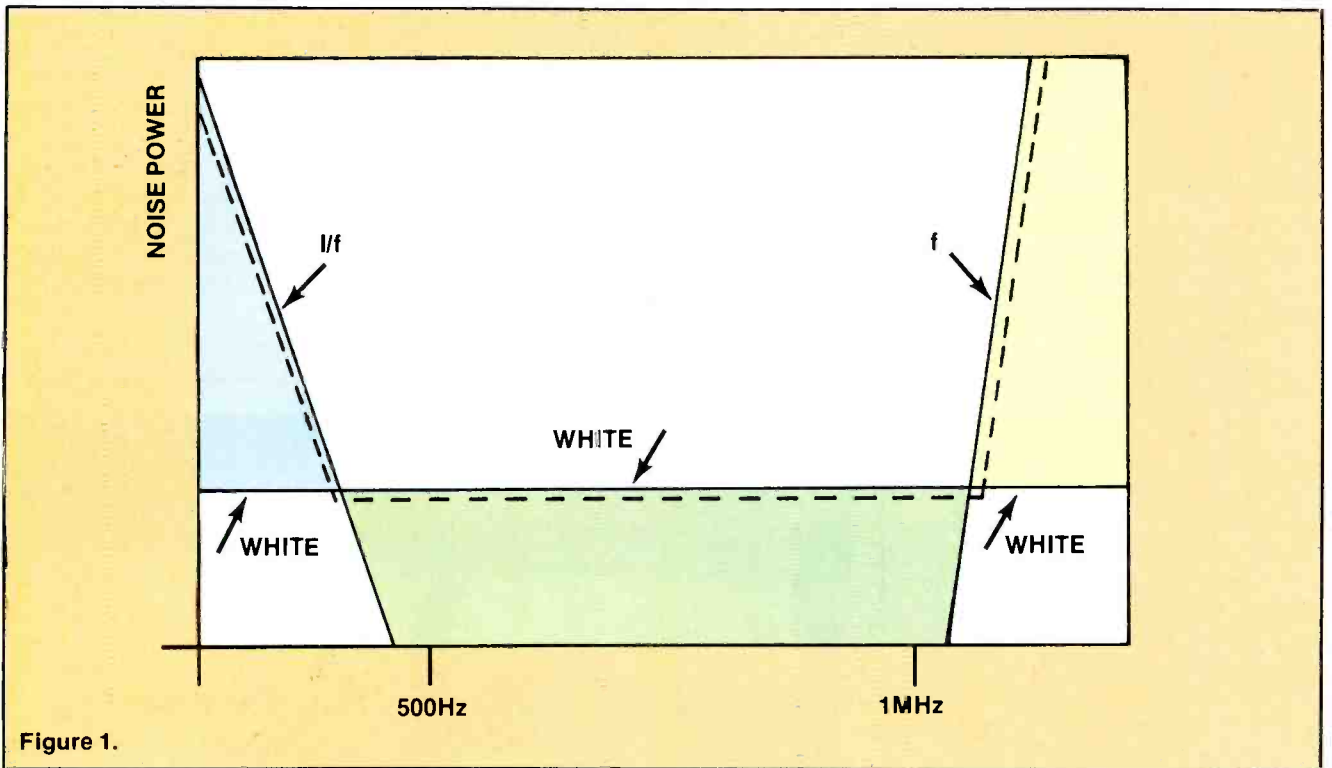

Your customer just paid good money for a service call. Don't let him blow it!

All your hard work and your customer's hard-earned money are wasted when a voltage surge hits. All it takes is a nearby lightning strike or the switching of a load within a building. RCA's Voltage Surge Suppressor can prevent this damage to sensitive electronic equipment, and assure you of extra profit on every service job you do.

Available in a 3-way version, SK403, and a single-socket version, SK401, the suppressor plugs into any 15-amp, 125-volt grounding receptacle or cord connector. If constantly overloaded, the suppressor will cut off power to equipment connected to it, guarding against unprotected operation and signalling the



need for a replacement suppressor.

Once they realize how much damage it can prevent, your customers will want to buy RCA's Voltage Surge Suppressor to protect their TVs, computers, sound systems, microwave ovens and other electronic equipment. Every SK403 and SK401 has been tested before leaving the factory. So why blow a perfect opportunity to protect a satisfied customer? Stock up on RCA's profitable Voltage Surge Suppressors today.

Call your RCA SK Distributor or write: RCA Distributor and Special Products Division, 2000 Clements Bridge Road, Deptford, NJ 08096, Attn: Sales Promotion Services.

RCA
SK Replacement
Solid State

Partition noise occurs in amplifying devices because, at any one instant, the number of charge carriers that divides off to the input circuit changes. Figure 2 shows what happens in a bipolar transistor. Part of the emitter current divides off to the base and the rest goes to the collector.

At any instant of time, the actual number of charge carriers that go to the base is different from the number that go the next instant. This continual change in base current produces the partition noise.

Figure 1. All amplifying devices generate three types of noise; $1/f$, "white" noise, and f noise.

Figure 2. In a bipolar transistor, the division of emitter current between the base and the collector is constantly changing. This creates partition noise.

Figure 3. In an FET all the charge carriers go to the drain. There is, therefore, no partitioning of current, and so no partition noise.

Now look at the FET in Figure 3. All of the charge carriers go to the drain, so there is no moment-to-moment change in the drain current, and no partition noise. That is one reason for the superior noise characteristic of FETs.

Another of those ideas that was put into my head, and that I had to research, was that a common base (and grounded grid) amplifier has less noise than other configurations.

I think that idea came from the cascode amplifier. The load-side amplifier is connected in a common-base (or grid) configuration because of its high-frequency gain. The low-noise characteristic of the cascode amplifier is due to its high gain and, therefore, high signal-to-noise ratio.

Cascode amplifiers were first used to replace pentodes in high-frequency circuits. Pentodes have a high partition noise. Because triodes were used in the cascode (CAscaded triODE) amplifier, the noise was greatly reduced. It

didn't have anything to do with the grounded-grid circuit. This discussion of noise will be continued.

Unlearning

I can't help wondering if any other technicians besides myself had to undo a lot of things they had learned.

On my very first day of teaching, I was told to sit in on another instructor's class. A student asked the instructor why he couldn't get a signal on his car radio when he drove through a tunnel.

The instructor told him it was because the radio waves were too long to get into the tunnel. I made a serious enemy by laughing. I honestly thought he was joking.

That story may sound funny, but it has a serious side. I think instructors and writers have a very serious responsibility to get the story right. At the same time, it is important to remember that no one is perfect. An honest mistake should not be treated as a capital offense.

ES&T

Chassis — General Electric EC-A
PHOTOFACT — 1918-1

1

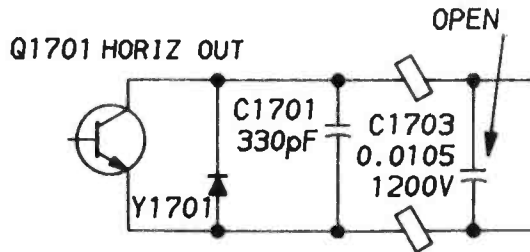

Symptom — HV begins then stops; shut-down.
Cure — Check capacitor C1703, and replace it if open.

Chassis — General Electric EC-A
PHOTOFACT — 1918-1

2

(NO SCHEMATIC)

Symptom — Receiver goes dead erratically, but dial lights are on.
Cure — On power-supply module, solder jumper wires from W18A to Q18B to W18C to W18D.

Chassis — General Electric EC-A
PHOTOFACT — 1918-1

3

(NO SCHEMATIC)

Symptom — Dim raster without picture or sound.
Cure — On power-supply module, solder jumper wires from W11A to W11B to W11C.

Chassis — General Electric EC-A
PHOTOFACT — 1918-1

4

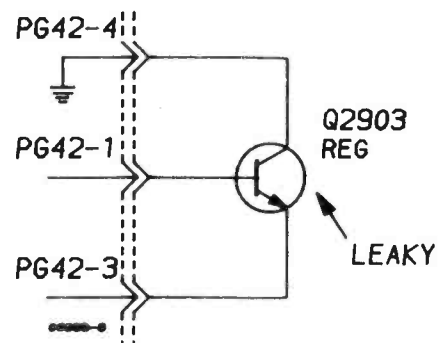

Symptom — Might shut itself off while operating, or go into shut-down when switched on.
Cure — Check regulator transistor Q2903, and replace it if leaky.

Chassis — General Electric AC-C
PHOTOFACT — 1979-1

5

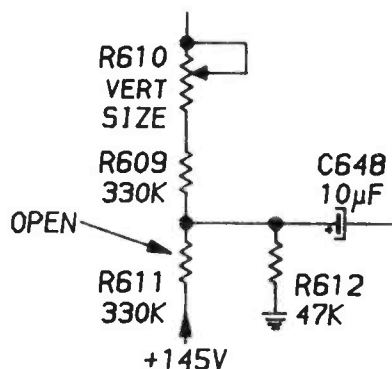

Symptom — No vertical deflection (one horizontal line).
Cure — Check resistor R611, and replace it if open.

Chassis — General Electric AC-B
PHOTOFACT — 1925-1

6

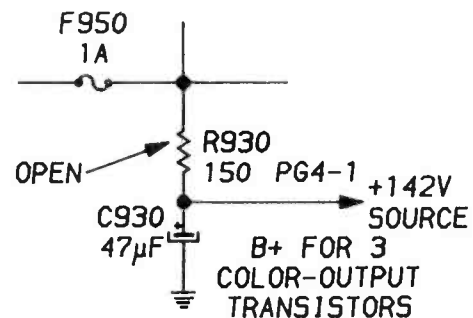

Symptom — Excessively bright picture with retrace lines, without much control of brightness.
Cure — In the power supply, check resistor R930, and replace it if open.

A.W. Sperry Instruments introduces
**The 4½ digit DMM with
 the 3½ digit price.**

Another A.W. Sperry Instruments first! Our new **AWS DM-7010** combines the precision of 4½ digit readings with all the most-wanted features you've been looking for. We've even included a built-in frequency counter (up to 200KHz)! With 9 functions and 33 ranges, the **AWS DM-7010's** expanded capability can't be beat!

And that's not all! Included among the special functions built into the **DM-7010's** small, self-contained housing are: conductance, diode test and an instant audible continuity check. The **DM-7010** has a basic DC Volt accuracy of 0.05% and loads of built-in safety features.

You'd expect to pay \$300 or more for an instrument boasting this kind of performance, yet the **AWS DM-7010** can be yours for a low **\$170!** Now there's no need to pay more for the accuracy and quality you need in a DMM.

For more information, call your distributor or A.W. Sperry Instruments, Inc., P.O. Box 9300, Smithtown, N.Y. 11787. **800-645-5398 Toll-Free** (N.Y., Hawaii, Alaska call collect 516-231-7050).

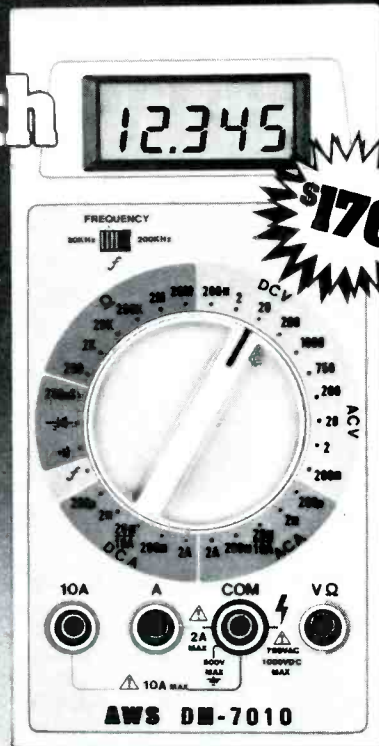

A.W. SPERRY INSTRUMENTS INC.
The Measurable Advantage.

Circle (12) on Reply Card

Answers to the Quiz

See page 10 for Questions

1. B. If the current is sufficient to heat the coil and its core, there may be a slight change in inductance. The effects of the other choices are much greater.

2. B. If you increase it enough, you will end up with a straight piece of wire and minimum inductance.

3. C.

4. A. The iron gets shorter. This is called the *magnetostrictive effect*.

5. B. At some frequency, the coil inductance will resonate with the distributed capacity. Above that frequency the opposition will decrease with a further increase in frequency.

6. B. You cannot magnetically saturate the *air core* of an inductor. When answering questions such as this, you must assume that the increase in current will not be destructive, and, also, that it will not change the shape of the coil due to heating of the conductor.

7. C. Don't blame me for this one. It was on a copy of a company exam that was sent to me for evaluation. Number 28 wire has the smaller diameter, so the coil of this wire size has more turns.

8. B. Eddy currents are reduced that way. A better choice of core material is needed to reduce hysteresis loss.

9. A. They are called *diamagnetic* materials.

10. C.

The VIDEO CONNECTION

Editor's note: "The video connection," a series of articles designed to make sense out of the increasing complexity of interconnecting televisions, VCRs, stereos and other home electronic products with antennas, cable and satellite feeds, was planned as a 5-part series. The first three parts appeared in *ES&T* in March, April and May 1985, respectively. Because of unforeseen circumstances it became necessary to interrupt the series after the third part, which appeared in the May 1985 issue of *ES&T*.

We are now able to complete the series. Here is part four of "The video connection." Part five, the final installment, will appear in the October issue.

By Martin Clifford

The first move in making connections of add-on or outboard units depends on the existing intercomponent wiring, and probably means beginning with the antenna. If there is already an antenna, you must first determine the type of download, which will be

either 300Ω twinlead or 75Ω coaxial cable. If an antenna is to be installed, then determine which of these two downloads to use: 300Ω line can be easier to install and costs less, but 75Ω coaxial cable has the advantage of not picking up extraneous interfering signals.

Figure 1. Multiple TV-receiver operation from a single antenna. A is a 300Ω-to-75Ω matching transformer; B is a 4-way signal splitter; C consists of suitable lengths of coaxial cable; D represents VHF/UHF band separators. This setup assumes the antenna signal is strong enough to drive four TV sets that may be in widely spaced locations.

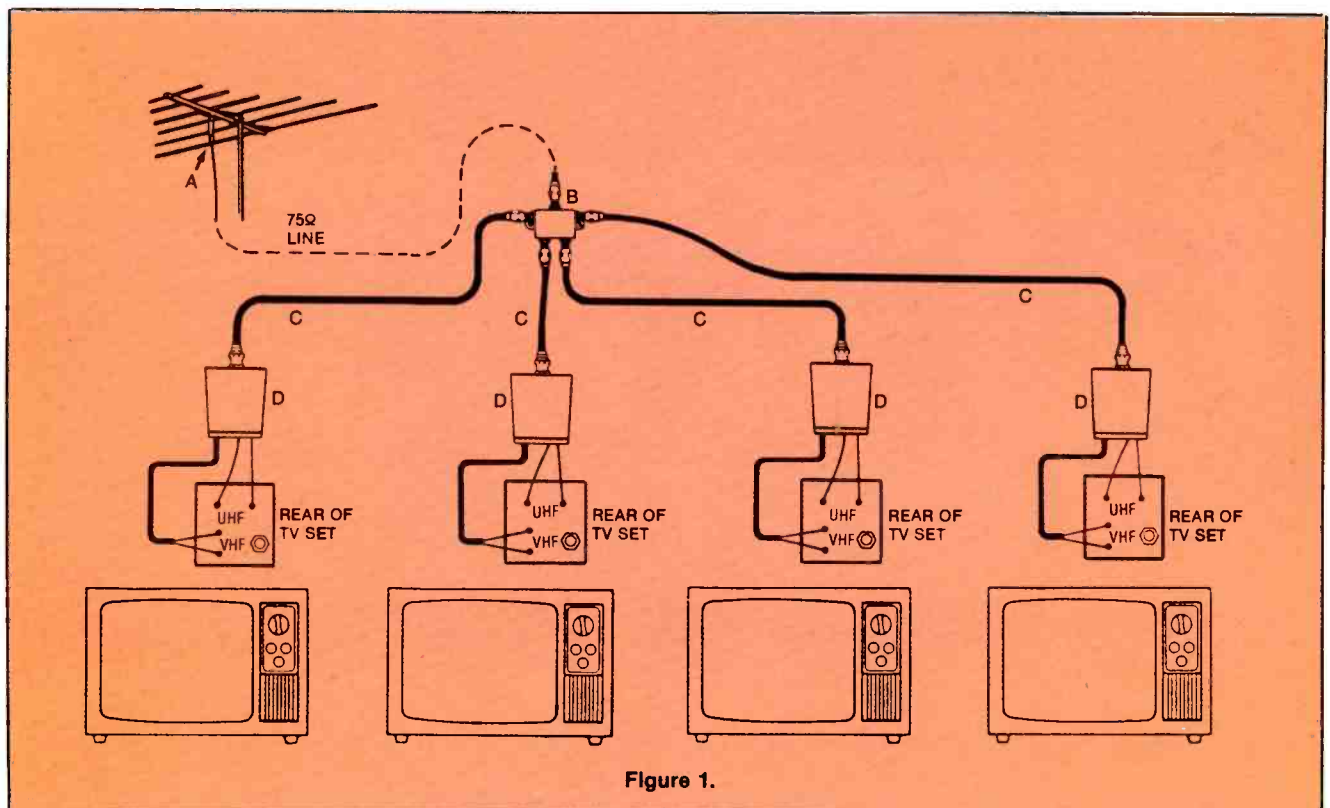

Figure 1.

These aren't the only configurations, however. If the TV sets have 300Ω inputs, it could be easier to use 300Ω downlead, and if the inputs are 75Ω, then coax could be a better choice.

75Ω antenna and multiple TV sets

If the 300Ω antenna is transformer-coupled to a 75Ω downlead (A) and the TV signal is to be connected to two or more TV sets, then the arrangement in Figure 1 can be used. Assuming signal strength from the antenna is adequate and that a pre-amp isn't required, the first component to be inserted in the signal line from the antenna is a signal splitter (B). Even if just two TV sets are to be connected, a 4-way signal splitter could be used, with two of the ports left unconnected, but reserved for adding more TV sets at some later date.

Coming out of the splitter are four selected lengths of coaxial line (C). The lengths depend on the distance from the signal splitter to the TV receivers, consequently these lengths will vary. The splitter is exactly that, a component that is intended to cut the signal into four equal parts. The input impedance to the splitter is the same as its output impedance, and in this example is 75Ω.

The next component in the line is a band separator (D), one for each of the TV sets; these can be mounted right at each receiver. The band separator has two outputs: One of these is the VHF signal, and the other is UHF. The kind of band separator to use will depend on the types of inputs to the TV set. These may be both 75Ω for VHF and UHF; both may be 300Ω; or one might be 75Ω and the other 300Ω. The band separators must be selected accordingly.

Multiple televisions with 300Ω downlead

If the downlead is 300Ω as shown in Figure 2, then the transmission line could be connected to a 300Ω-to-75Ω balun (A). The three TV sets then could be wired-in just as

shown earlier in Figure 1; except for the use of the balun (A) and the terminator (E), Figure 2 is the same as Figure 1.

The terminator

In Figure 1, all four ports of the signal splitter are used. However

in Figure 2, a new component has been included: a terminator. It is simply a 75Ω resistor housed in an F-type male connector. The purpose of the terminator is to supply a proper impedance match for the unused port. Without the terminator, TV signals reaching the open

Current issues

Interested in exploring new technologies? You'll find Sams high-tech books enlightening and up-to-date. They cover the latest advancements in audio, computers, electronics and telecommunications.

Written by respected industry authorities, Sams books reflect state-of-the-art technology. So you can be sure you're working with the most reliable, accurate information available. Whether you're studying audio or electronics design. Learning how to troubleshoot with an oscilloscope. Exploring the operation, installation and servicing of landmobile, marine and personal radio communication equipment. Or discovering the principles of logic design using CAD. You'll have all the information you need, from the basics to practical applications.

Whether you're a hobbyist, a student, an engineer or a technician, you'll find our books clear, concise and easy-to-read with many helpful illustrations.

See for yourself what powerful learning tools Sams books can be. Visit your local Sams dealer. Or to order direct, call our toll-free number.

CMOS Cookbook (2nd Edition), No. 22459, \$17.95

IC OP-AMP Cookbook (3rd Edition), No. 22453, \$18.95

Computer-aided Logic Design, No. 22436, \$19.95

Microcomputer Projects With The 68000, No. 22458, \$21.95

Troubleshooting With The Oscilloscope (2nd Edition), No. 22473, \$16.95

How to Read Schematic Diagrams (4th Edition), No. 22457, \$14.95

Principles of Digital Audio, No. 22388, \$19.95

Landmobile and Marine Radio Technology Handbook, No. 22427, \$19.95

Modern Recording Techniques, No. 24451, \$18.95

Radio Systems for Technicians, No. 22464, \$12.95

800-428-SAMS

Ask for Operator 166.

In Indiana, call 317-298-5566

SAMS

Howard W. Sams & Co., Inc.
A Subsidiary of Macmillan, Inc.
4300 West 62nd Street
Indianapolis, IN 46268



Circle (13) on Reply Card

September 1985 *Electronic Servicing & Technology* 55

port will be reflected to the antenna, possibly interfering with the incoming signal. A consequence could be ghost images on the three TV sets. If two ports are left unused (that is, if just two TV sets are to be connected), then each of the two unused ports should be fitted with a terminator.

TV broadcast and cable input to a single TV set

The fact that cable-TV service is available doesn't preclude the use of an antenna for pickup of television broadcasts from local stations. Again, the method of connection is influenced by whether the download is coaxial cable or 300Ω line.

Figure 3 shows an arrangement that can be used when the transmission line is 300Ω. The component identified as *B* in the illustration is an inexpensive 2-position 75Ω coaxial switch. It has a twin input receiving signals from either a cable converter or an antenna. The switch, generally a horizontal slide type, should be mounted so that it is convenient for use, possibly on top of the TV set. One

of the two inputs is 75Ω; the other is 300Ω. Connected to the output is a band separator (*D*). In this example, the band separator not only supplies individual VHF and UHF outputs, but the output for VHF is 75Ω; that for UHF is 300Ω.

When making connections as shown in Figure 3, if the download is 75Ω, then it would be convenient to follow through and use 75Ω connections throughout the installation.

A similar setup is shown in Figure 4, except that the download from the antenna is 75Ω cable. The same coaxial switch is used as in Figure 3, but since the inputs and outputs of the switch (sometimes called a coaxial A/B switch) are 75Ω, no impedance matching is required. However, at the 300Ω antenna, a matching transformer (*A*) is used.

The choice of band separator (*D*) will be determined by the impedances of the antenna inputs on the TV set. Consequently, when making wiring installations, it is desirable to take a look at the download, and, also, at the antenna terminal board on the receiver.

Alternate multiple TV approach

There are often different methods of making video connections. As an example, Figure 5 shows another way of system wiring compared to those shown earlier. Because the use of splitters and switchers causes signal loss, it is possible, particularly in fringe areas, for multiple TV installations to have weak pictures.

The input line identified by the letter *G* can be a signal input from any video signal source, such as an antenna, a cable TV signal, a VCR or the output of a satellite TV receiver. There are two boxes

Figure 3. Connecting an antenna and cable TV to a single TV set. The 300Ω download is impedance matched (*A*) to the video switcher (*B*). The cable converter also delivers its signal to the switcher. *C* indicates coaxial cable. The VHF and UHF signals are separated by add-on component *D*.

Figure 4. Antenna and cable input to a single TV set. The 300Ω antenna uses a 300Ω-to-75Ω balun (*A*). All the inputs and the output of the coaxial (A-B) switch are 75Ω. Various lengths of coaxial cable (*C*) are used. The band separator (*D*) has a 75Ω input, 300Ω for UHF output; 75Ω for VHF output.

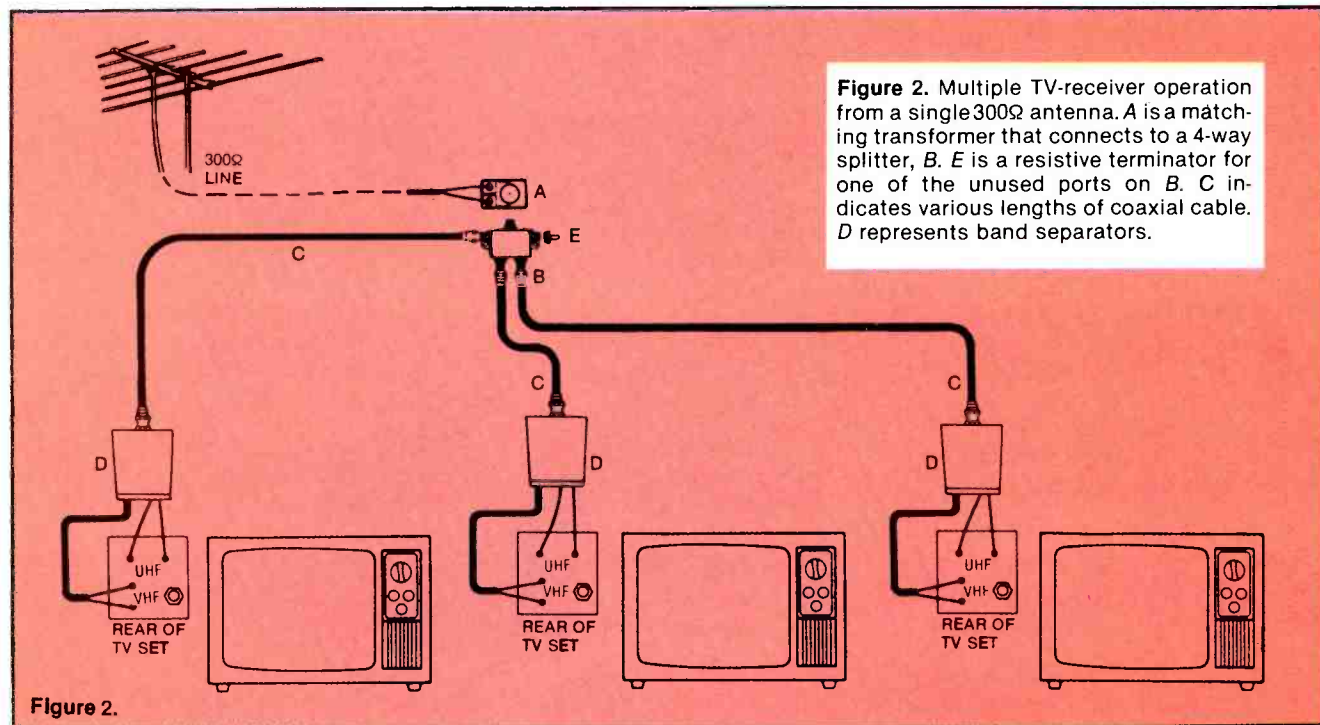
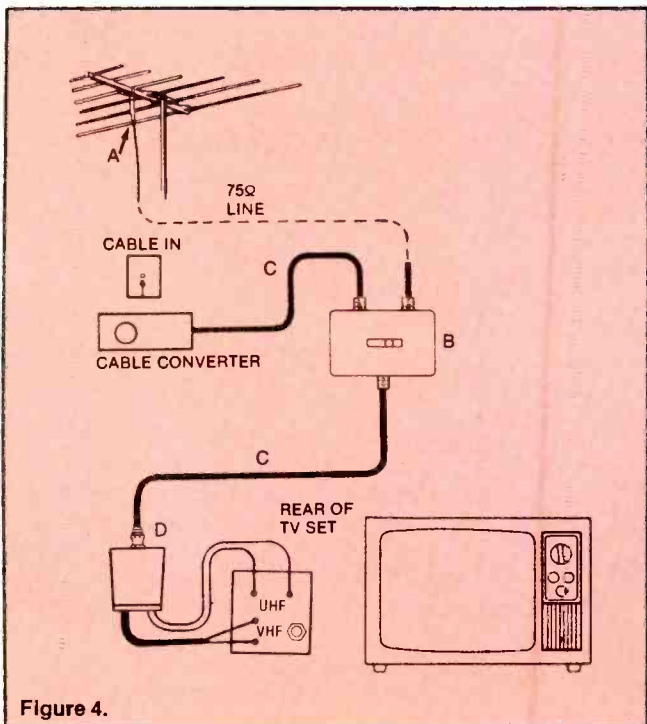
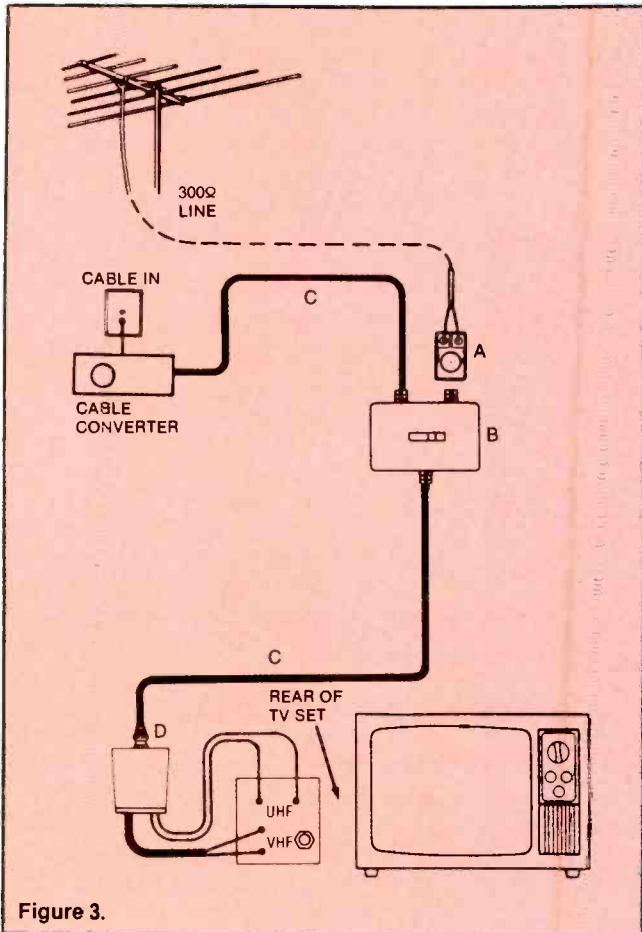

Figure 2. Multiple TV-receiver operation from a single 300Ω antenna. *A* is a matching transformer that connects to a 4-way splitter, *B*. *E* is a resistive terminator for one of the unused ports on *B*. *C* indicates various lengths of coaxial cable. *D* represents band separators.



With so many electronic catalogs out there, how does MCM stay at the top?

We strive to bring you the best catalog in the industry. You'll find our 132 page catalog packed with a full line of test equipment, computer accessories, speakers, CATV equipment, television parts and the largest selection of original Japanese semiconductors in the country. *Our product selection puts us at the top; our low prices and fast delivery are what keep us there!*

CALL TODAY FOR YOUR FREE COPY OF CATALOG #10!
CALL TOLL FREE
1-800-543-4330
 (IN OHIO CALL 1-800-762-4315)
 (IN HAWAII OR ALASKA 1-800-858-1849)

MCM ELECTRONICS
 A DIVISION OF PREMIER INDUSTRIAL
 858 East Congress Park Drive
 Centerville, Ohio 45459
 513-434-0031

SOURCE NO. ES-6

Circle (14) on Reply Card
 September 1985 *Electronic Servicing & Technology* 57.

marked *D* with each representing a pre-amplifier. The one inserted in the line from the signal source is the better location because it supplies gain for all four TV sets, but if this isn't feasible, then the pre-amplifier can be positioned be-

tween the hybrid splitters (marked *E*). Note that one of the TV receivers is fed from the first splitter, a 3-port type, while the other three sets are driven by the second splitter.

There are some advantages to

this arrangement. TV set No. 1 will receive a stronger signal than the three other TV sets. It has a signal loss caused only by the first splitter. To make up for the signal loss, another pre-amplifier can be inserted. This is marked as *D* also. The signal from the second pre-amplifier is then brought into a 4-port splitter. The output of this splitter supplies signals to the three TV sets, each of which is equipped with a VHF/UHF band separator.

No distinction is made here about impedance matching. The choice of the input impedance for the first signal splitter (*E*) could be determined by the impedance of the download. Thus, if the transmission line from the antenna is 300Ω , then the first splitter should have a 300Ω input. However, the impedances of the other components, the second pre-amplifier, the second splitter and the band separators (*C*) probably would be decided by the impedances of the VHF and UHF antenna terminals on the TV sets. The easiest way to handle this problem is to start with the impedance of the download, and the impedances of the TV set inputs. These may all be the same, in which case the connecting problem is simplified. More likely they will be different.

Multiple boosters

The usual routine in the average home is to install one TV set, then another, until two or more sets are in use. Just because the signal input from an antenna is strong enough to produce a good picture on one set, does not mean a second, and possibly a third set as well, will work satisfactorily from the same antenna. A good arrangement, if a signal booster (pre-amplifier) is to be used, is to position it near the point at which the signal becomes weak.

Figure 6 illustrates another installation possibility. Here the antenna delivers a signal to a TV set through a VCR. The output of the VCR drives the first TV set via a signal splitter using one of the

Quick charge cordless soldering iron. Up to 125 electronics joints per charge. Total recharge in less than 4 hours. Isolated tip design. One of more than 2 dozen ISO-TIP and STERLING irons available. Write for free catalog and name of nearest distributor.

A Hot Tip on Cordless Soldering

No. 7700
QUICK CHARGE
Cordless
Soldering Iron

**ISO-TIP®
STERLING®**

WAHL CLIPPER CORPORATION
Sterling, Illinois 61081 • (815) 625-6525

Circle (25) on Reply Card

ARTICLE REPRINTS

Interested in ordering custom reprints of an article from this issue? Reprints of articles about your company or products can be valuable sales and marketing tools. For information, call or write Kelly Hawthorne, Intertec Publishing Corp., P.O. Box 12901, Overland Park, Kansas 66212; (913) 888-4664.

*minimum order 1,000 copies

ports of that splitter. Apparently that TV set has no need for further signal amplification. The second port of the splitter is connected to a pre-amplifier and from that amplifier to the second TV set.

Note that the booster remains connected to the ac power line. It has no *on/off* switch nor is one required; the booster uses so little electrical current that it can remain permanently connected.

Stereo sound

TV sets are now being manufactured with a stereo sound capability, but even with older sets it is possible to have what could be called pseudo stereo.

Figure 7 shows the arrangement. The audio output of a VCR and the headphone output of a TV set are connected to a Y adapter. The output of the Y adapter is connected to the auxiliary input terminals of the stereo pre-amplifier or of the integrated amplifier if that is what is being used in the hi-fi system.

Either one of the auxiliary input terminals of the audio amplifier can be considered as the left sound channel input, and the other as the right. Some amplifiers have switchers for the sound channels but if not, then the inputs to the auxiliary terminals can be transposed if required. In the event that the TV set does not have an earphone output, clip a pair of connecting leads to the voice coil terminals of the speaker. If the TV set has a pair of speakers, connect to either one or the other.

Connecting the videodisc player

Some video users aren't interested in recording and want playback functions only, and so their preference for signal sources would be broadcast television and a videodisc player. The connections are shown in Figure 8.

The 300Ω antenna is connected to a 300Ω-to-75Ω matching transformer with an *F* type output (point A). For outdoor use, it should come supplied with a slip-on

rubber boot. The connecting cable to the output of the transformer can be RG6 or RG59U.

The VHF and UHF signals are parted by a band separator at *B*. While this unit has 75Ω input, it has a 75Ω output for VHF and

300Ω output for UHF. The 300Ω output can be connected directly to the UHF terminals on the back of the TV set, or, if additional wire length is needed, to a 300Ω line extension device (*D*). Unlike splitters and band separators, the exten-

Miniature Hand Tools

Acu-Min[®]
Precision Miniature
Tools for Industry

- ⊖ Slotted Screwdrivers
- ⊕ Cross Recess Drivers
- English Hex Drivers
- Metric Hex Drivers
- Open End Wrenches
- Socket/Nut Drivers
- ⊗ Spline Drivers



Used World-wide by Professionals

- | | | |
|---------------|-------------|-----------------|
| • Industry | • Aerospace | • Ordnance |
| • Instruments | • Test Labs | • Audio Visual |
| • Assembly | • Re-work | • Field Repairs |



by *Moody* TOOLS INC. (401) 885-0911

42-60 Crompton Avenue, P.O. Box 230, East Greenwich, R.I. 02818

When **A**ccurate **M**iniature tools are required, specify **A**cu-**M**in by **M**oody

Circle (15) on Reply Card

MAKE SURE you get paid for every inch of wire sold

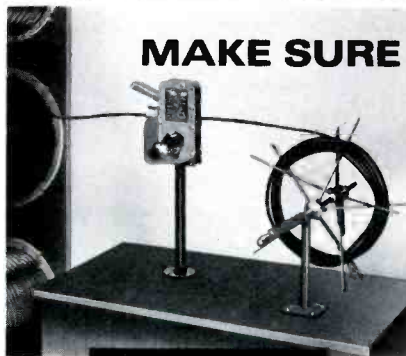

Hykon

EXACT MEASURING is a must when you retail coaxial cables, audio cables, and electronic/electrical wires. You can work confidently and quickly... yet keep close control... with **HYKON WIRE METERS** and **REELS** set up on a counter or as a portable combo. Wire up to 1" diameter pulls from stock through the meter onto take-up reel for neater delivery. Write for details or call us at
AREA 216 821-2320

MANUFACTURING CO.
Post Office Box 3800-ET Alliance, OH 44601

Circle (16) on Reply Card

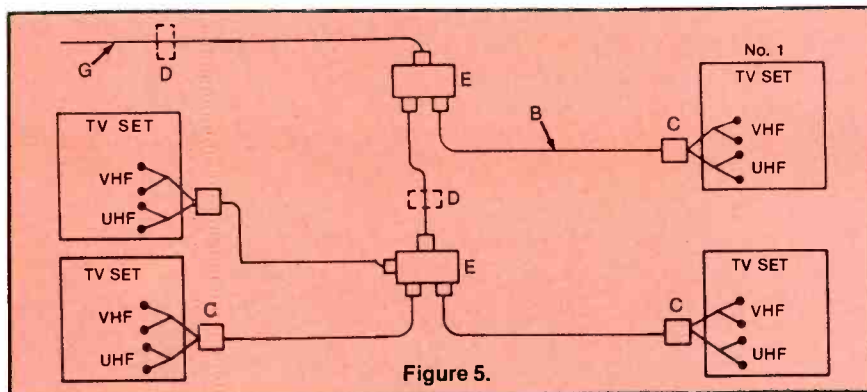

Figure 5. Multiple TV installation using two signal pre-amplifiers, *D*. If UHF signals are being used, the pre-amplifiers must be capable of amplifying both VHF and UHF. The pre-amplifiers should have a gain of at least 20dB, preferably more.

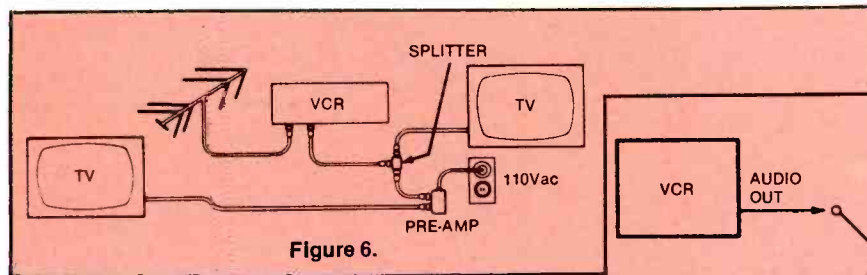

Figure 6. First TV set following the VCR has adequate signal input but booster is used for the second television.

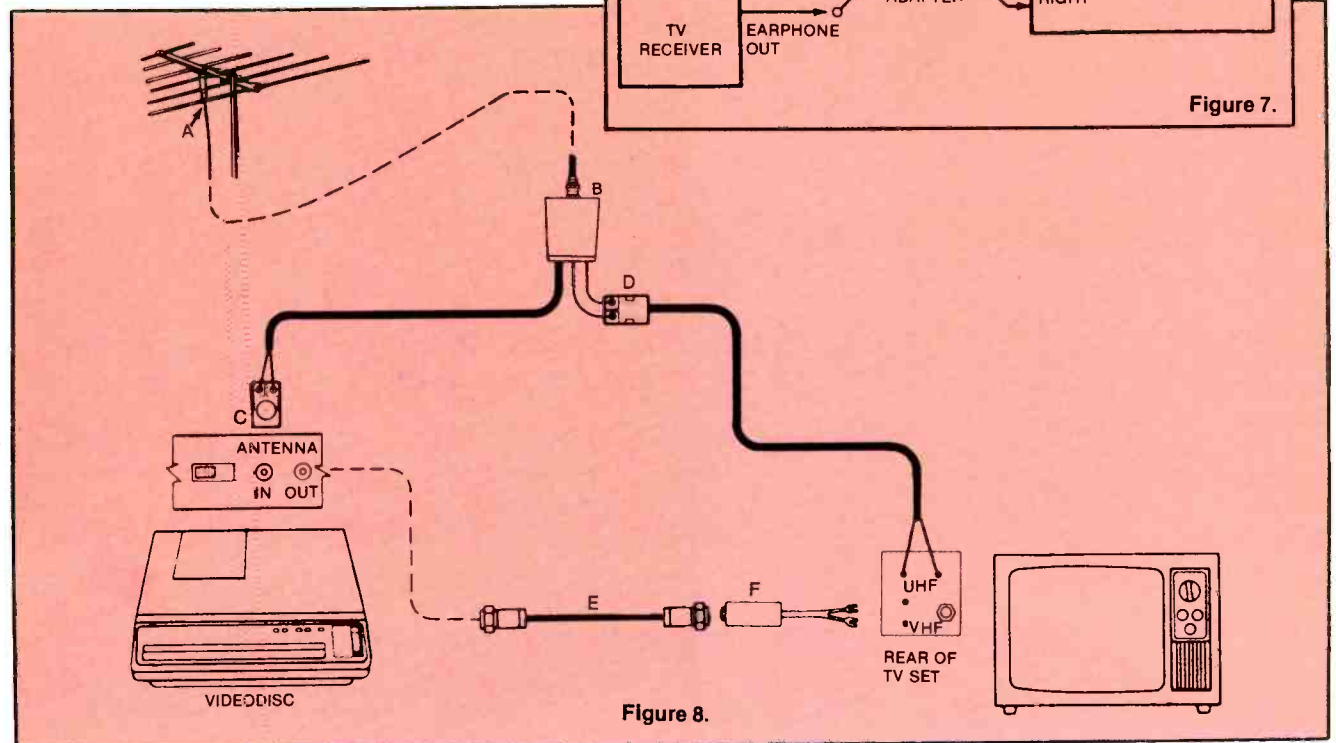
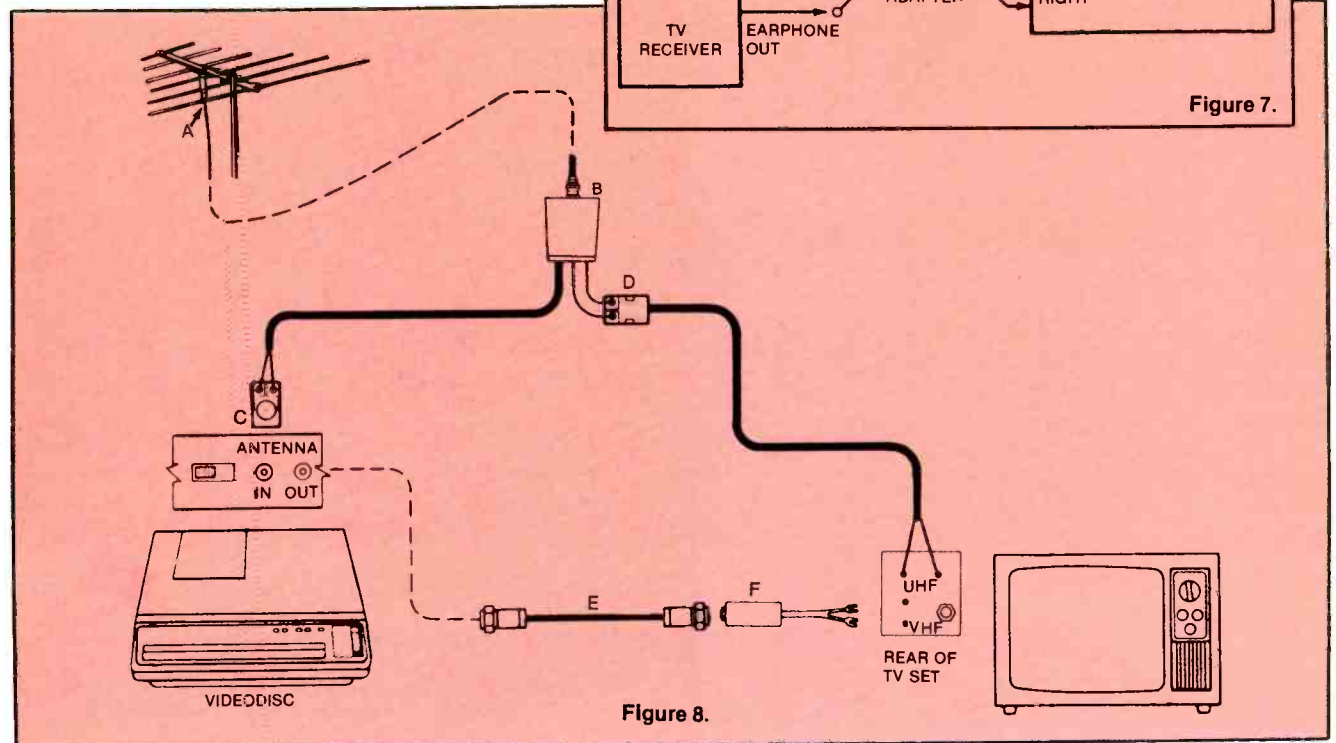

Figure 7. Method of obtaining pseudo stereo by using the audio output of a TV set and a VCR.

Figure 8. Antenna and videodisc player used as signal sources.



sion unit itself (aside from the wire supplied with it) does not cause any signal loss.

The second output port of the band separator is coaxially connected to the antenna input terminals on the videodisc player.

This input is ordinarily intended for 75Ω input, but if it is 300Ω, then the band separator shown at *B* is 75Ω, and so it can be connected by 75Ω cable (*E*) to the UHF input of the TV set. If that input is 300Ω, use a 75Ω-to-300Ω transformer, as at *F*.

The videodisc will be equipped with a slide switch to permit selection of either channel 3 or channel

4 as the display channel for the videodisc. Output of the videodisc is 75Ω, and so it can be connected by 75Ω cable (*E*) to the UHF input of the TV set. If that input is 300Ω, use a 75Ω-to-300Ω transformer, as at *F*.

ESV

Continued from page 26

tions for eccentricity are being tightened on the new HiFi VHS, Beta and 8mm recorders as more performance is being demanded from these consumer formats. Attempting to determine head protrusion with a gauge designed for eccentricity measurements may result in a damaged head tip and at best will give you erroneous protrusion readings. The opposite is not true, however, and a mechanical head protrusion gauge can be utilized for measuring drum eccentricity with precision.

Step up to track down problems

So now you have some information to assist in knowing how to diagnose the cause of snowy picture problems. If you don't have any equipment other than your index finger and don't mind being wrong occasionally, you can start your learning curve. The next step up in cost is with the inductance head checker (one for Beta and one for VHS) at less than \$100 each. If you can locate what the inductance specifications should be, this is a workable method. The next step up in cost is the mechanical head

protrusion gauge. The gauge provides a quantitative reading for the amount of wear or life on any head tip. (Figure 3.) The next step up in price is a microscope; this is a good way to find foreign deposits on video heads but it is difficult to see the amount of wear or remaining life of the head tip. This requires a learned, subjective analysis. Finally, the signal substitution method; this electronic method is integral with test equipment that performs other useful test functions for VCR repair. You may want to contact the manufacturers to obtain complete specification data sheets and actual prices on methods described in this article. (See Figure 4.)

Within three to five years, estimate that all 20 million current VCRs will require new heads. That's 20 million! If you plan to service VCRs, it would be a good idea to know how to diagnose their wear and tear to affirm why and when replacement is necessary.



Graham is general manager of Tentel, Campbell, CA.

Small size. Small price.

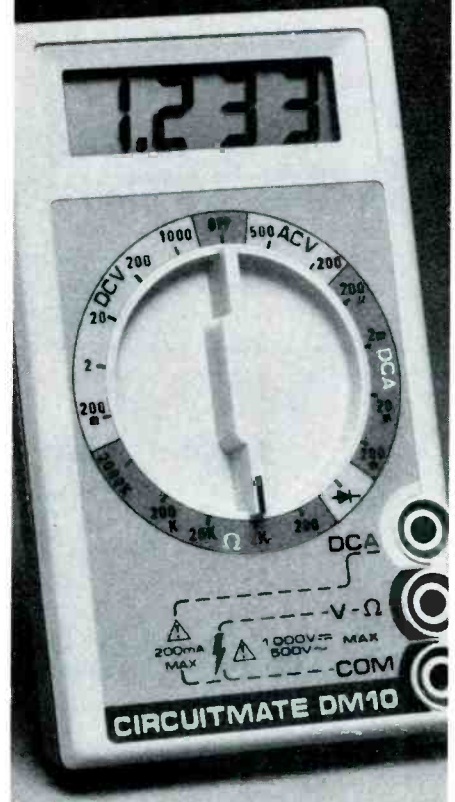

DM10 . . . \$39.95*

Don't settle for an analog multimeter. Now, for the same low price you can have a reliable digital multimeter that's easier to use, easier to read, and is three times more accurate.

- DCV accuracy 0.8% of reading
- 1/2" LCD digits
- 5 Functions (ohms, DCA, ACV, DCV, Diode check)
- Overload protection (250V in ohms)
- 250 Hour battery life.

This is the ideal carry-one-anywhere meter. Tool box, glove box, shirt pocket. Whenever you need to make a measurement, you're ready.

Also available, featuring a continuity beeper, is the DM10B for only \$49.95.*

Both models include a 9V battery, safety test leads, and operator's manual.

Get one now at your local Beckman Industrial distributor. *Suggested list price.

Beckman Industrial
A subsidiary of Emerson Electric Co.
630 Puente Blvd.
Brea, Calif. 92621

Beckman Industrial™

Circle (17) on Reply Card

Testing head wear

Method	Contact	Cost
Finger-inspection	Mother nature	Priceless
Inductance	Leader Instruments 380 Oser Ave. Hauppauge, NY 11788 516-231-6900	Less than \$100 (Beta/VHS)
Mechanical head protrusion measurement	Tentel 1506 Dell Ave. Campbell, CA 95008 408-379-1881 800-538-6894	Less than \$500 (Can also be used for eccentricity readings)
Microscope	Local scientific supply house	Variable \$500 to \$1500 (Depending on features and lighting)
Electronic substitution	Sencore 3200 Sencore Drive Sioux Falls, SD 57107 605-339-0100 1-800-843-3338	\$3000 (With many other functions)

Figure 4.

Troubleshooting Tips

Lines in picture Sharp model 19E75

(Photofact 2014-1)

Vertical lines (resembling yoke ringing) were on the left and right edges of the screen. These lines were phase-locked to the picture, which indicated

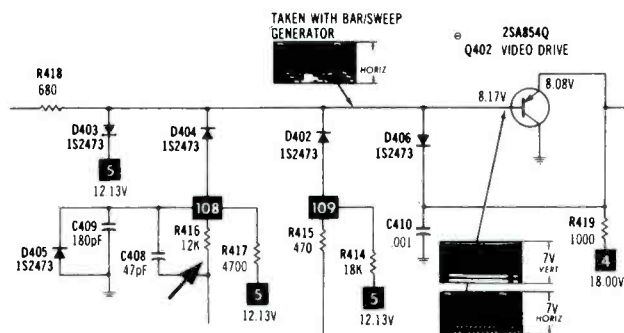

they originated from the horizontal-sweep circuit. (Stable *horizontal* lines usually are from the vertical-sweep circuit.)

Filter capacitors were the first suspects, but they were checked and found to be normal.

Next, the video stages were scoped and unwanted pulses were found in the output signal. By scoping various stages of the video system, I narrowed the problem down to the blanking signal and the Q402 luminance driver for the color-output power transistors.

Resistance tests in the Q402 circuit located an open in R416 (12K), and normal performance without vertical lines in the picture was obtained after a new R416 resistor was installed.

William A. Grimm
Uniontown, PA

For free sample guidelines on submitting Troubleshooting Tips and Symcures for publication, write to:
Troubleshooting Tips/Symcures
Electronic Servicing & Technology
P.O. Box 12901
Overland Park, KS 66212

NESDA Computer Group

COMPUTER SALES AND SERVICE DEALERS
WORKING TOGETHER

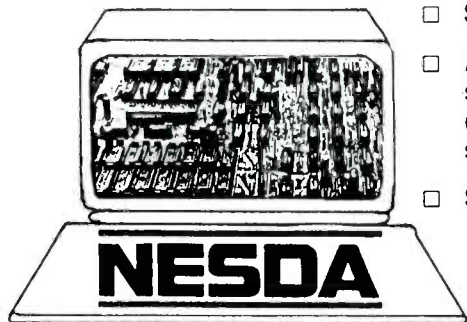

- Service training.
- Assistance in selecting in-house equipment and software.
- Specialized software for service management.
- Factory contracts for service literature and parts.
- Involvement in a stable and productive national trade association.

FOR MORE INFORMATION SEND BUSINESS CARD TO:
NESDA COMPUTER GROUP, 2708 WEST BERRY STREET
FORT WORTH, TEXAS 76109; PHONE (817) 921-9061

MOVING?

If you're planning a move in the near future, don't risk missing an issue of Electronic Servicing & Technology. Please give us 6-8 weeks notice if you're planning on changing your address. Just write in your new address below and mail this coupon, WITH YOUR SUBSCRIPTION MAILING LABEL, to:

ELECTRONIC

Servicing & Technology

P.O. Box 12901, Overland Park, KS 66212

For address change you MUST affix label from cover here. Print new address below.

Name _____
Address _____
City _____
State _____ Zip _____

Books

Editor's note: *Periodically Electronic Servicing & Technology features books dealing with subjects of interest to our readers. Please direct inquiries and orders to the publisher at the address given, rather than to us.*

The Encyclopedia of Electronics, Stan Gibilisco, editor in chief; Tab Books; 1024 pages; hardbound only, \$58.

There are more than 1300 photos, drawings, charts, formulas and tables illustrating the 3000-plus topics arranged alphabetically in this encyclopedia. Cross-referencing and indexing speed finding answers for those sometimes-pesky questions. This resource book goes beyond term definition to provide expanded information on each topic.

The encyclopedia also explains relationships to other electrical and electronic operations

Tab Books, Blue Ridge Summit, PA 17214.

The Illustrated Dictionary of Electronics, third edition, by Rufus P. Turner and Stan Gibilisco; Tab Books; 892 pages; \$34.95 hardbound, \$21.45 paperback.

This revised, updated and enlarged edition of a classic reference identifies and defines more than 27,000 vital electronics terms, acronyms and abbreviations. More than 2000 new terms have been added to this edition. Electronics, electricity, communications, computers and emerging technologies have been covered in a basic, non-technical style. Both authors are well-known in the field: Turner, a licensed professional engineer, has written several electronics books for Tab; among Gibilisco's published works is "The Encyclopedia of Electronics," also reviewed in this issue.

Tab Books, Blue Ridge Summit, PA 17214.

Handbook for Electronics Engineering Technicians, by Milton Kaufman and Arthur H. Seidman; McGraw-Hill Book Company; \$39 hardbound.

Electrical engineering technicians will find that this handbook will not require an extensive background in high-level engineering principles and techniques. It was written to meet the day-to-day needs of electronics technicians.

Twenty four in-depth sections are arranged in the same format, breaking down each topic as follows: definition of terms and parameters; types and characteristics of components; analysis of the basic and special functions; detailed practical problems and clearly worked out solutions; and clarifying charts tables, monographs and illustrations.

Seven new chapters, each written by a recognized authority in that particular field, have been added to update readers with advanced theoretical and practical applications.

McGraw-Hill Book Company, 1221 Avenue of the Americas, New York, NY 10020

ES&T

PRB . . . OFFERS THE PROFITABLE SYSTEM FOR SELLING VIDEO RECORDER BELTS

The PRB stock number describes the required belt. You just size the belt on our handy MEASURE-A-BELT gauge and you'll have all the info needed to find your belt. The PRB System is fast, easy and profitable!

For details on our profitable belt system and the complete line of PRB electronic components just call toll free . . .

National 1-800-558-9572
 Business Number 1-414-473-2151
 In Wisconsin 1-800-242-9553
 TLX 4994411 PRB USA
 In Canada call collect: 1-613-225-5003

PRB
 PROJECTOR RECORDER BELT
 200 Clay Street, Whitewater, WI 53190

Circle (19) on Reply Card



*Don't drive all over town
 When just a phone call away...*

E.S.I. Electronics can fill all your Receiving Tube Needs!

We can save you time and money with our low prices and fast service. We've got the hard to find old and new types. Over 1,000,000 pieces in stock for same day shipping. At ESI we will stay in the receiving tube business as long as you need them!!

Remember... We also stock resistors, IC's, capacitors, transformers, tools, cables, solder aids, connectors, switches, speakers, antennas, and much more!!

ORDER BY PHONE:
800-645-4720

(OR IF BUSY) (516) 379-2202

E.S.I., Inc.
 3171 Hempstead Turnpike
 Levittown, New York 11756

Circle (20) on Reply Card

ATTENTION ELECTRONIC TECHNICIANS



Highly Effective Home Study BSEE Degree Program for Experienced Electronic Technicians
Our New Advanced Placement Program grants Credit for previous Schooling & Professional Experience. Advance Rapidly! Our 40th Year!
FREE DESCRIPTIVE LITERATURE!
Cook's Institute of Electronics Engineering
P.O. BOX 20345, JACKSON, MS 39209

Circle (26) on Reply Card

NEW!... 5th edition



The new 5th edition of Tech's Guide to Pricing is a step by step succession of progressive pricing tiers by product category... a totally new concept, a formula that guarantees success...

- TV •VCR's •Discs
- Cameras •Digital Audio •TVRO's
- Computers
- Telephone products
- + much more

FREE with order... 36 page booklet... filled with ideas, answers to questions you won't find in any other publication!



For details call **1-800-228-4338**
Mon/Fri 8/5 C.S.T.
You won't be disappointed!

Circle (27) on Reply Card

Use ES&T classified ads

ATTENTION TECHNICIANS

- ★ JOB OPENINGS
- ★ MONTHLY TECHNICAL TRAINING PROGRAM
- ★ BUSINESS MANAGEMENT TRAINING
- ★ LOW COST INSURANCE
- ★ CERTIFICATION
- ★ TECHNICAL SEMINARS

All of this in a nonprofit international association for technicians

FIND OUT MORE:



R.R. 3 Box 564
Greencastle, IN 46135

Products

PCB repair system

Automated Production Equipment's model PRS-475 PG is a complete PCB repair system, which features a microprocessor-controlled plating center, capable of depositing 50 micro inches of gold for mil-spec edge connector repair. The versatile PRS-475PG also includes the following accessories: desoldering handpiece, solder iron, thermal tweezer with three blade sets, reflow solder tool with practice kit, miniature drilling system and circuit repair kit.

Circle (75) on Reply Card

Metrawatt system multimeter

BBC-Metrawatt/Goerz has introduced a low-cost 4¾-digit system multimeter that is available with a choice of three interfaces. Called the Metrawatt M 2110, the instrument may be ordered with a factory-installed



IEEE-488, RS-232-C or Centronics bit-parallel interface.

Basic dc accuracy is ±0.05 percent + one digit. The instrument includes all standard functions (dc and true RMS Vac and current, and resistance) and two extra capabilities: dB and capacitance.

Circle (76) on Reply Card

Bench-style DMM

North American SOAR announces model 5430 4½-digit multifunction bench-style DMM. This unit is microprocessor controlled, using SOAR's custom LSI chip set. The 5430 is a 25,000-count DMM. Special features include diode test, continuity beeper, data hold, peak hold with a dc acquisition time of 5ms and ac, of

250ms; relative test, 3½-digit select for fast survey measurements and a comparator circuit for making *go, no-go* tests (with comparator data output via a rear panel connector).

Circle (77) on Reply Card

Soldering iron tip cleaner

The model EL-200, available from *Duple Tech.* is a soldering tip cleaner that cleans a soldering tip



in less than one second. The moist sponge rollers surround the tip without twisting or turning the soldering iron, eliminating solder drops. It is available in 110V and 230V versions.

Circle (78) on Reply Card

16-channel logic analyzer

A logic analyzer that costs less than units with comparable performance characteristics has been introduced by the *Instrumentation Division of Interplex Electronics.* Called the IE-1620, this portable 16-channel, 20MHz logic analyzer has an acquisition speed up to 20MHz and acquisition memory capacity of 2000 x 16 bit words. A 200-word reference memory can

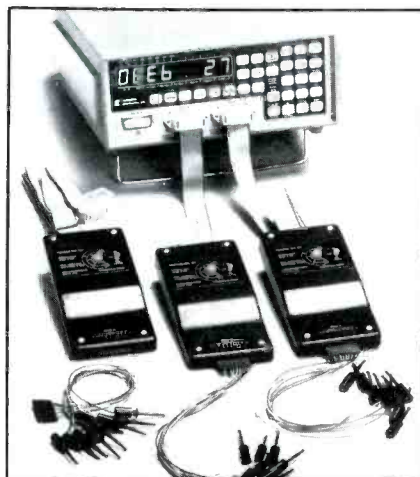

be loaded from the acquisition memory and is edited through the keyboard. The reference memory is non-volatile, so that data is retained when the instrument is turned off.

The IE-1620 has 16 data channels and can be expanded to 32 channels to permit monitoring and recording the activities of up to 32 different circuits simultaneously. Also, synchronous and asynchronous analysis can be performed.

Circle (79) on Reply Card

Identify terrestrial interference

Data and maps of microwave routes for each state are available from *Microwave Filter Company*. Installers of TVRO systems may

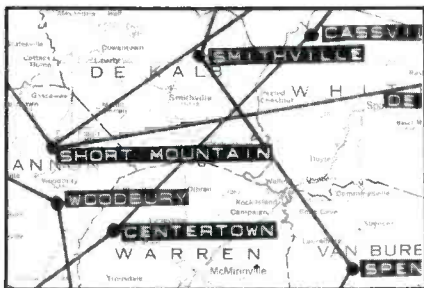

purchase the information to identify sources of interference that can hamper antenna reception. The data include the transmit-and-receive site for each microwave path in a specified state, frequencies authorized for each path, path length in miles and azimuth of path. Also provided for each transmit site, are the FCC call letters, latitude and longitude, county, closest city, transmitter height, user of the link and a short location description. Maps are available for each state. Texas, Florida and California are broken into two maps each because of their size. Delivery of data is two weeks; maps require about six weeks.

Circle (80) on Reply Card

Logic comparator

This logic comparator is designed to test 14-, 16-, 18- and



20-pin, TTL, DTL or compatible CMOS ICs on the board. The model 800 Comparator by

Kobetron detects function failures at full system speed with a "known good" IC inserted in the logic comparator. The logic comparator is easily programmable by setting the LED display with the last two or three numerical digits of the IC to be tested. Indicator lamps provide good or fault condition by a one-step testing function. Capable of testing up to 1000 ICs.

Circle (81) on Reply Card

Signal sampler and calibrator

AVCOM of Virginia announces a signal sampler and calibrator, model SSC-70, for use with the PSA-35 portable spectrum analyzer.

The first function of the SSC-70

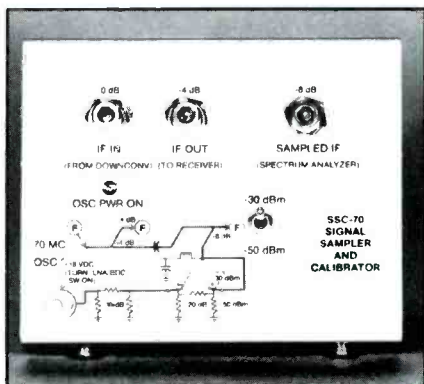

is to sample TVRO downconverter IF signals in the 30MHz to 200MHz range. The IF signal is looped through the SSC-70 between the downconverter and the satellite receiver. Tuning voltage present in the IF coax is passed unaltered from the receiver to the downconverter. The IF signal is sampled and is available on the sampled IF F-fitting. The PSA-35 spectrum analyzer is connected to this port and the IF signal can be accurately measured and examined.

Circle (82) on Reply Card

Pneumatic desoldering

Automated Production Equipment Company's, model EX-600 provides high performance pneumatic desoldering at a budget price. Model EX-600 includes a plug-in temperature control module, no-clog desolder hand-piece, tool stand and pneu-vac foot pedal that converts air pressure of 60-120 psi into high-flow vacuum.

Circle (83) on Reply Card



Take the Guesswork Out of VCR Service

Tentel now has 3 products for quickly and easily diagnosing the mechanical performance of VCR's. The **Tentelometer®**



tape tension gauge is the world standard for tape tension measurements to prevent skewing and interchange problems. The TSH gauge series finds problems causing edge damage and binding cassettes, the two biggest causes of tape destruction. The New HPG-1 head protrusion gauge represents a breakthrough for an accurate, easy to use method of determining head life; takes the guesswork out of video head replacement. The HPG-1 for Beta, VHS, and U-matic VCR's measures head tip protrusion and drum eccentricity in both microns and ten thousandths of an inch.

These 3 products allow the entire mechanical performance of a VCR to be measured in a few minutes by only removing the top cover of the VCR.

Call or write for details—We want to help.

TENTEL

(408) 379-1881

1506 Dell Avenue

800/538-8894

Campbell CA 95008 Telex 910 590 8001

Circle (21) on Reply Card



SINCE 1950

- LEADING SPOKESMAN
- TRADE INFORMATION DISPENSER
- WATCHDOG
- NATESA SCOPE
- STANDARDS YARDSTICK
- CONSUMER RELATIONS
- PROBLEM SOLVER
- CONCISE PRACTICAL BUSINESS OPERATIONS MANUAL
- SERVICE CONTRACT MANUAL
- CUSTOMER PLEASING PROFIT PRODUCING ORDER FORMS
- PARTS PROCUREMENT EXPEDITOR
- SERVICE BUSINESS
- DIVERSIFICATION PLANS
- TECHNICIAN DEVELOPER

6210 So. Pulaski Rd. • Chicago, Illinois 60629

OPTIMA ELECTRONICS

TO ORDER CALL TOLL FREE 1-800-327-0224

POPULAR CAPACITOR ASSORTMENT BAGS (PC Mount)

- mfd (1),(2.2),(3.3),(4.7),(10),(22),(33),(47), (100),(220),(330),(470) -12 pcs. @ 50V \$3.25
- mfd (.47),(1),(2.2),(3.3),(4.7),(10),(22),(33),(47) -9 pcs. @160V \$3.30
- mfd (1),(2.2),(3.3),(4.7),(10),(22),(33),(47) -8 pcs. @250V \$3.95
- mfd (1),(2.2),(3.3),(4.7),(10),(22),(33) -7 pcs. @ 350V \$3.75
- mfd (1),(2.2),(3.3),(4.7),(10) -5 pcs. @450V \$2.95

Call and ask for our current flyer.

HORIZONTAL OUTPUT TRANSISTORS

- \$2.50 ea. Min. 10, 1 yr. Warranty
- 1308K Sanyo
- 2SD1341P Sanyo
- Rembrandt top-of-set Ant. \$ 9.95
- Video Cassette Rewinder \$27.00
- VHF/UHF FM Dist. Amp (#425) \$13.95

MONTHLY SPECIALS

TRANSISTORS & I.C.'s...MIN. 10, CAN MIX

- | | | |
|---|--|---|
| <input type="checkbox"/> 2SD1398 .. \$2.80 | <input type="checkbox"/> 221-103... \$4.95 | <input type="checkbox"/> DM133 .. \$5.95 |
| <input type="checkbox"/> 2SC1114 .. \$3.75 | <input type="checkbox"/> 221-132... \$2.95 | <input type="checkbox"/> DA101 .. \$4.95 |
| <input type="checkbox"/> MN8303 .. \$3.95 | <input type="checkbox"/> 221-140... \$7.95 | <input type="checkbox"/> HA1388 .. \$2.95 |
| <input type="checkbox"/> 2SC1124 .. \$.95 | <input type="checkbox"/> 221-158-01 \$3.95 | <input type="checkbox"/> HA1396 .. \$5.50 |
| <input type="checkbox"/> 2SD871 .. \$4.25 | <input type="checkbox"/> 221-175... \$7.95 | <input type="checkbox"/> HA1398 .. \$2.50 |
| <input type="checkbox"/> CX101G .. \$10.50 | <input type="checkbox"/> 221-178... \$4.95 | <input type="checkbox"/> UPC1181 .. \$1.00 |
| <input type="checkbox"/> CX103 .. \$10.50 | <input type="checkbox"/> 221-179-01 \$7.95 | <input type="checkbox"/> UPC1182 .. \$1.00 |
| <input type="checkbox"/> CX143A .. \$10.50 | <input type="checkbox"/> 221-190... \$7.95 | <input type="checkbox"/> UPC1185H .. \$2.25 |
| <input type="checkbox"/> UPC1388H2 \$3.95 | <input type="checkbox"/> 221-193... \$5.95 | <input type="checkbox"/> 2SC2580 .. \$2.95 |
| <input type="checkbox"/> UPC1367C .. \$3.75 | <input type="checkbox"/> 185-9-01 | <input type="checkbox"/> 2SA1105 .. \$2.95 |
| (Subs CX557A) | (triac) \$1.50 | |

GENERAL

- Sanyo Focus Div. Z0064 (min. 3) \$12.95
- Sanyo Focus Div. Z0040 (min. 3) \$12.95
- FO241 Color Flybacks \$15.60
- FO1123 \$15.54
- FO192A \$18.28
- FO239 \$20.28
- FO260 \$19.20
- Quick Connects for 59U (#859) 100 for \$32.00

Quantity Prices Available

Letters of credit and all checks placed on deposit with Bank of Hallendale, FL. VISA & Master Charge accepted. Min. order \$75. FOB Dania, FL. Catalog \$3, refundable upon order.

SEND CHECK OR MONEY ORDER TO:

OPTIMA ELECTRONICS

2022 Tigertail Blvd., Dania, FL 33004

Phone (305) 920-3550 TOLL FREE: 1-800-327-0224

Circle (22) on Reply Card

Readers' Exchange

For Sale: Sams Photofacts folders 36 through 496, \$2 each or all 350 for \$500, plus shipping. Call or write for complete list. Rider's volume 1 AM-FM tuner manual; Sams tape recorder service manuals, TR-1 through TR-4, and TR-11; Sams recorder changer service manuals CM-2 through CM-9, RC-11 and RC-12. All service manuals \$3 each, plus shipping. *John Brouzakis, RD 3, Box 602B, Charleroi, PA 15022; 412-483-3072.*

For Sale: New Fluke model 8020B, \$175 or best offer; new HD-100 Beckman with RF221-22 probe, \$150 or best offer. *Stanley Todorow, G3398 S. Grand Traverse, Burton, MI 48529.*

Wanted: Service manuals and/or schematics for Acoustic model 116 musical instrument amplifier manufactured by Acoustic Control, Van Nuys, CA; service manual and/or schematic for Project/one model Mark IIIC stereo receiver distributed by Playback; service manual only for Kenwood KR-7600 stereo receiver. Will copy and return or will pay. *Stuart Koniarski, Archer/Brighton TV and Electronics, 4826 S. Wolcott, Chicago, IL 60609; 312-427-6542.*

For Sale: B&K Precision model 415 solid-state sweep/marker generator, all probes and manual, perfect condition, \$300 or offer. *Lerma Audio & Video, 2645B N. Sycamore St., Arlington, VA 22207; 703-534-9087.*

For Sale: Used chassis parts for color television: Zenith, RCA, Sony and others; includes yokes, flys, tuners and more. *Gad Barzily, 84-39 120th St., Kew Gardens, NY 11415.*

Needed: Schematic or information about Triplett FM-AM signal generator model 3433. Will cover expenses. *Phil Clay, 5583 Roanoke, Kalamazoo, MI 49000.*

Wanted: VCR Sams and manufacturer's service manuals, VCR mechanical alignment tools, VCR home study training manuals and/or videocassette training programs. *L. Prasadam Flores, P.O. Box 8146, Santa Cruz, CA 95061; 408-423-7017, evenings.*

For Sale: 114 Sams Photofact sets, 131 to 899, or 28 Sams from 900 to 1922, \$39 per group—send s.a.s.e. for list. Manufacturers' TV data. Beitman's Supreme manuals: 15, for radio; 19, for television. B&K Precision E-400 sweep generator or Heathkit TS-4 alignment generator, \$39 each. Heathkit FM stereo generator IG-37 or frequency counter IB-1102, \$70 each. Tequipment D-52 dual-trace scope, probes and manual, \$250. All prices, postpaid. *Sunset Electronics, 3205-148th SE, Bellevue, WA 98007.*

Wanted: VCR, TV, stereo, telephone, test equipment and manuals. VA 62, VA68, Z meter, Sams Quick Facts, etc. *David Pirzadeh, 951 Elaine Court, Rohnert Park, CA 94928; 707-585-8647.*

Wanted: IC No. TA7153P or GEIC 283. *L.O. Robensin, 4662 Esther St., San Diego, CA 92115.*

For Sale: Vertical input, horizontal frequency model PS-127; Sencore speed aligner, crystal-controlled, marker-added sweep output marker SM-158; Sencore TV sweep circuit analyzer model SS117; Sencore Align-O-Pak seven-in-one dc bias supply for tube or solid-state color and b&w television: model BE156, \$24. *Theresa Costantini, 538 Sharpless Road, Springfield, PA 19064.*

Needed: Service literature, including schematic for DoKorder model 1140. *M. L. Smith Electronics, Box 15387, Sarasota, FL 33579.*

Needed: Operating manual for Fairchild scope, dual trace model 766H 25-50MHz. *J.P.F., 1206 N. Cummings St., Los Angeles, CA 90033.*

For Sale: Motorola business-band radios, B&K TV alignment generator, Lampkin modulation meter. *Alvin J. Jacobson, 416 W. 2nd St., Williston, ND 58801.*

Needed: Capacitor CH-10, part No. 67A15-415, for Admiral TV chassis No. T43K10. Also, flyback transformer for Broadmoor TV model 3513. Please state price. *George Saylor, 2319 Parrish St., Philadelphia, PA 19130.*

Wanted: Sams Photofacts 0-1600 and 1900-up. *Chuck French, Box 412, Ridgeland, MS 39158; 601-956-7878 between 6:00 and 8:00 a.m. CDT.*

For Sale: 300 radio and TV tubes, \$300; model 944 Eico flyback and yoke tester, \$20; tube caddy free. You pay postage. *T. W. Benson, 204 Riverside Ave., Tallahassee, AL 36078; 205-283-4266.*

Plug in!

To the NESDA system.

YOUR BUSINESS is in the world's fastest changing industry. If you're not careful, you could find your business in the dark.

But, you don't have to stay there.

Through a system of local, state, and regional groups, the National Electronics Sales & Service Dealers Assn. (NESDA) keeps members up-to-date with the fast pace of advancing technology while offering:

- ◆ Managerial and technical training.
- ◆ Business contacts.
- ◆ Technical and management certification.
- ◆ Information on new products.
- ◆ Legislative activities that affect the industry.

Don't be left in the dark. Let the NESDA system work FOR YOU!

For more information and an application, write to:

NESDA, 2708 W. Berry St., Ft. Worth, TX 76109; Ph (817) 921-9061

Name _____

Bus. Name _____

Address _____

State _____ Zip _____ Phone _____

Member of State Local Assn. _____

For Sale: Older radio and TV parts (new, in boxes), tubes and servicing equipment, best offer. Send large s.a.s.e. for list. *Elmer J. Alderman, Route 2, Box 139, Madison, NC 27025.*

Needed: CB214, 225,249, 262 and 293. *Ernest F. Meade 502½ First Ave. West, Logan, WV 25601; 304-752-0010.*

Wanted: Sams AR 1, 2, 5, 11, 13, 17. Others for sale at \$3 each. *Jim Farago, P.O. Box 65701, St. Paul, MN 55165.*

For Sale: New Elenco logic probe model LP500, DT-100 transistor and diode tester, \$25 each—kits need to be assembled; TF26 Sencore cricket transistor test, fair condition but works, \$30; 10A variable auto transformer 120Vac input, 0-140Vac output, non-isolated, good condition, \$30 plus shipping; Elenco DMM model 1200 with high-low power ohms, \$45 (good working condition). Best offers. *Stan Todorow, 5166 Riverbend, Flint, MI 48507.*

Needed: Meter movement for Radio Shack Micronta FET-VOM model 22-209. Will pay shipping, postage, etc. Also, owner's manual and service manual for open reel DoKorder model 7050, and for open reel tape recorder Sony TC-270. Will pay for copies and postage. *John S. Boczar, 42 Edwards St., New Haven, CT 06511.*

Needed: Service manual for Fisher model 434, 2-4 channel radio receiver. Will buy or copy and return. *Charles D. Prater, Edna, KY 41419.*

For Sale: B&K 1477 scope, 15-18MHz, one year old; B&K 1250 NTSC generator, six months old. Both excellent, no scratches. *Lava's Music Centre, 75 Robinson St., Simcoe, Ontario N3Y 1W7, Canada; 519-426-6130.*

Wanted: Service manual and parts source for home stereo console model HSC-1. *Valentine J. Ambrose, Roadrunner Electronics, P.O. Box 441, Wildomar, CA 92395; 714-677-6114.*

For Sale: Sencore VA48 with AT218, TR219, Tb228—\$800; Sencore LC53 with FC221, SCR224—\$500; B&K 1472C oscilloscope, \$400; B&K 415 sweep marker generator, \$250; Heath IG-1275 Lin/Log sweep generator, \$300; Heath IB-3128 impedance bridge, \$160; Heath IG-5218 audio generator, \$100; Heath IG-5242 RF generator, \$100. All manuals and leads included; equipment never used commercially because of illness. *Lyle G. Clark, 36 Flag Road, Little Rock, AR 72205; 501-664-5174.*

For Sale: Radio and TV text books, Sams Photo manuals, auto radio manuals, Tekfax TV schematics, 1100 radio and TV tubes in original cartons, 85 percent off list plus shipping. Send s.a.s.e. for list. *M. Seligsohn, 1455 55th St., Brooklyn, NY 11219.*

Wanted: For VCR repairs—tape tension and spindle gauge, video test tape, etc. Also, Panasonic 12-inch picture tube No. A26JAS31X. *Ed Herbert, 410 N. Third St., Minersville, PA 17954.*

Wanted: Old tube-type audio driver transformers. (P-P plates to P-P grids) 10W or larger. Examples: Chicago BD-1, UTC LS-47, CG-53AX, Stancor A-4763, etc. *Mike Koch, Route 4, Box 20, Hagerstown, MD 21740.*

For Sale: RCA tube caddy with 300 tubes, \$250. *Douglas Haustein, 94 Winans Ave., Cranford, NJ 07016.*

For Sale: Sound level meter, H.H. Scott type 450-B, \$75; Hewlett Packard audio oscillator model 2001R, \$35; new 4-channel VHF pocket scanner, \$75. *J.L. Orysen, 2025 Sunkist Ave., Waukesha, WI 53188; 414-542-1271.*

Needed: Schematics and technical information for Magnus organ model 1400P, listed 657. Will buy or will pay for copying, or will copy and return. *A. Cappiello, 36 New Hyde Park Road, New Hyde Park, NY 11040.*

Needed: Solder tips for old WEN 250W gun. *Cal McAllister, Rucker's TV, 5208 Pershing, Fort Worth, TX 76107.*

For Sale: Conar 255 solid-state 6MHz oscilloscope with four probes, \$200 includes UPS, insurance; 12 NRI VCR repair lessons (new), \$200, includes mailing. *J.D. Maaks, 9163 Pine Springs Drive, Boca Raton, FL 33428; 305-487-4513.*

For Sale: Sola Electronics' type CV-1 constant voltage transformer, primary 95-130V, secondary 118V and 1.02A, \$25; VCR professional training course by NRI that includes two-hour VHS training tape and covers associated subjects, \$100; NRI basic and advanced CB communications course plus 41 Sams CB service manuals, \$200; Motorola Mobile Training Institute (MTI) FM 2-way professional radio communication course, \$100. All, excellent condition. *Clarence G. McKee, 9516 Zion Road, Rives Junction, MI 49277; 517-569-3139.*

For Sale: Original factory service manuals and schematics for television, tape recorders and radios. Send long s.a.s.e. for list. *Alvin Sydnor, 806 Meetinghouse Road, Boothwyn, PA 19061.*

Wanted: Back issues of *Radio Electronics*—October 1984, all issues of years 1982 and 1983. *J.G. Shoemaker, 600 First St., Leechburg, PA 15656; 412-842-8321.*

BS&T
TV

3S-Wick®

the most dependable desolder system... is also the least expensive.

Price per 5' Spool

NO. OF SPOOLS	3S-WICK®	SODERWICK®	CHEMWICK®
1-19	80 ^A	1.65 ^B	1.30 ^C
20-24	80	1.65	1.10
25-99	80	1.35	1.10
100+	75	1.08	.99

A—Reg. Trade Mark of Spring, price list 6/1/84
B—Reg. Trade Mark of Solder Removal Co., price list 4/1/83
C—Reg. Trade Mark of Chemtronix, price list 6/1/84



Our Patented 3S-Wick de-solder braids deliver everything you've ever wanted in a desoldering system. Fast acting. Absolutely safe. Unlimited shelf life. And most important—just 80¢ per spool...and even less in large quantities. Get the performance you need—and save money, too!

3S-Wick® covered by U.S. Patent 4,078,714 - 4,081,575, 4,133,291

FOR FREE SAMPLE
CALL TOLL FREE

1-800-628-8862

Distributor Inquiries Welcome

Circle (23) on Reply Card

CA28 UNIVERSAL PICTURE TUBE ADAPTER

NOW YOU CAN USE YOUR CRT/RESTORER/REJUVENATOR/CLEANER ON ANY COLOR CRT YOU DO NOT NEED TO BUY A NEW CRT TESTER. SAVE HUNDREDS OF DOLLARS. "THIS IS THE ONLY ADAPTER YOU WILL NEED" — USE ON NEW IN-LINE & ONE-GUN TUBES —

If your tester is the CLEANER/RESTORER type or the REJUVENATE type, you can use the function on your present machine or any Color Tube listed from a 9" to a 26," including foreign types. Checks Quintrex, Japanese Miniature Base, Japanese In-Line, Sylvania, and GE 90 Degree In-Line, New Sony Trinitron, Zenith Special In-Line, European 110 degree in-line, Sylvania 100 degree Color Tri-Potential, RCA 90 degree In-line, 110 degree Color, 90 degree Button Base, Large Trinitron, Small Trinitron.

Use with CRT Tester/Restorer/Rejuvenator.
CHECKS: QUINTREX-IN-LINE — TRINITRON — TRI POTENTIAL — PINLESS — JAPANESE — EUROPEAN 90°; 100°, 110° ALL CRT'S
VIDEO GAMES — COMPUTER TERMINALS, COLOR T.V. SIZES 9" thru 26" SCREENS.
MONEY BACK GUARANTEED

to solve all your CRT Testing problems, Obsolescence Proof Perpetual Set-Up Manual, CA28 Adapter Kit with Sockets.



****CHECKS OVER 2500 COLOR TYPES****
*****REPLACES OVER 65 ADAPTERS*****
B&K, BELTRON, SENCORE, CONAR, HEATHKIT REM, EICO, RCA, ALL OTHERS

Call Toll Free
1-800-331-9658

FREE: Limited Offer (With Purchase) — New Infra-Red Hand Unit Emitter Detector — Tests all TV & Cable I/R Transmitters.

A MUST FOR THE TV TECHNICIAN

CALL US OR WRITE
COD. Send Check or Money Order. CA-28 Kit \$61.95, add \$2.00 shipping and handling. Visa & Mastercard accepted.
DANDY MANUFACTURING CO.
2323 Gibson, Muskogee, Oklahoma 74403
918-682-4286

Circle (24) on Reply Card

Literature

RCA Distributor and Special Products Division announces the publication of an updated version of its "RCA Drawing Number to Stock Number Cross Reference" (Form 1F6932) that covers parts for all RCA consumer instruments except VCRs and cameras; a separate publication, "Replacement Parts for Videocassette Recorder Instruments Cross Reference" (Form 1F6627), that also has been updated, covers the cross-reference information for VCRs and cameras.

Circle (125) on Reply Card

An interchangeability guide listing replacements for more than 450 commonly used monochrome data display tubes has been published by **Philips ECG, a**

North American Philips Company. The 4-page guide cross references each of more than 450 original equipment CRT part numbers to the correct Philips ECG replacement tube type. Industry numbers are listed in easy-to-find alphanumeric order. The tube types listed in the guide replace data display tubes used in video, alphanumeric and graphic display monitors, computer terminals and word processors.

Circle (126) on Reply Card

The catalog 85-DTI-4 from **Davle Tech** features 40 pages of tools and equipment for electronic and telecommunications manufacturing, field service and labs, as well as for schools and hobbyists. The full-color, glossy catalog includes soldering and desoldering tools, wire-wrapping tools, testing and troubleshooting tools, assembly products and aids of various types. The catalog also features a product line of low-cost tools and products especially for education and home use.

Circle (127) on Reply Card

PMC Industries has released its power console catalog featuring ac line filters, voltage surge/spike suppressors and deluxe outlet boxes for use with microcomputers, microprocessor-based instruments and sensitive scientific instruments.

The catalog lists six ac line filters, five spike/surge suppressors, five deluxe outlet boxes and a ground-fault interrupter.

Circle (128) on Reply Card

A 46-page, illustrated catalog offered by **Sola**, a unit of **General Signal**, details the company's power protection products. The Distributor Products Catalog No. 718 is the first publication to combine information on the company's entire line, including power conditioners, power line monitors, uninterruptible power systems (UPS), standby power sources (SPS) and power supplies.

The catalog augments products information with performance charts, diagrams and mechanical specifications



Circle (129) on Reply Card

Classified

Advertising rates in the Classified Section are 75 cents per word, each insertion, and must be accompanied by payment to insure publications.

Each initial or abbreviation counts a full word.

Minimum classified charge is \$15.00.

For ads on which replies are sent to us for forwarding (blind ads), there is an additional charge of \$25.00 per insertion to cover department number, processing of replies, and mailing costs.

Classified columns are not open to advertising of any products regularly produced by manufacturers unless used and no longer owned by the manufacturer or distributor.

FOR SALE

AUTOMOBILE RADIO and tape replacement parts. Delco, Chrysler, Philco-Ford, Motorola, Panasonic and many others. Large inventory. Laran Electronics, Inc., 3768 Boston Road, Bronx, NY 10469. (212) 881-9600. National (800) 223-8314, NY State (800) 446-4430. 1-85-tfn

SCRAMBLED TELEVISION, encoding/decoding. New book. Theory/circuits, \$9.95 plus \$1 shipping. Workshop, Box 393ES, Dept. E, Bethpage, NY 11714. 1-85-tfn

TUBES—Receiving, Industrial and Semi-conductors, factory boxed. Free price list. Low, low prices. **TRANSELETRONIC INC.**, 1365-39th St., Brooklyn, NY 11218E, 800-221-5802, 212-633-2800. 8-85-2t

TV TROUBLESHOOTING: Over 70 illustrated problems-solutions of difficult repairs. Also, 12 steps to easier TV repair. Send \$12.00 to Jones, 407 Morningbird Court, Niceville, Florida 32578. 7-85-6t

STAR I—100% guaranteed IBM compatible computer, 128K, detached keyboard, two disk drives \$1,185. Available in kit form. Service shop management, inventory programs available. Wholesale computer parts. Free catalog. Astro, Rt. 9W, Stony Point, N.Y. 10980, 914-942-2173. 6-85-4t

TV TROUBLE ANALYSIS TIPS. Over 300 symptoms/remedies by circuit area; tough ones over the years. Save time and money. Send \$12.50 to CHAN TV, 8151 Grandview Rd., Chanhassen, MN 55317. 1-85-tfn

MAKE TELEPHONE answering machine servicing simple & professional. Without tying up your phone lines, our ring simulator will activate any machine on the market. You can hear the outgoing message, give your message, and also have the availability to check machines that have remote capability. Send your check for \$85.00 made payable to PSI, INC., to cover cost of machine shipping and handling or call (201) 845-6669. PSI, Inc. is located at: 34, Route 17 North, Paramus, New Jersey 07652. 4-84-tfn

SONY—PANASONIC—RCA—ZENITH EXACT REPLACEMENT PARTS—SONY PARTS AND TRINITRON SPECIALISTS. LARGE INVENTORIES. CALL 516-678-1700 OR WRITE WITH PART NEEDED. GREEN TELE-RADIO, 172 SUNRISE HIGHWAY, ROCKVILLE CENTER, NY 11570. 1-25-tfn

INDIVIDUAL PHOTOFACT FOLDERS (Not sets) #1 to #1400. \$3.00 first-class postpaid. Loeb, 414 Chestnut Lane, East Meadow, NY 11554. 8-85-5t

CABLE CONVERTERS. Lowest price. Dealer inquiries accepted. Quantity Discounts, FREE CATALOG. P.G. Video Corp., 61 Gatchell St., Buffalo, NY 14212. 5-85-6t

BOOTLEGGERS BIBLE for CB Modification \$12.95, CB Radio Repair \$10.95. Linear Amplifier Planbook \$14.95, kits, etc. Catalog \$1.00 refundable—APS, POB 263 Newport, R.I. 02840 401-846-5627. 12-84-tfn

HOW TO START a small electronics shop at home. Make extra money. Build as large as you want. How to get business, manage the shop, calculate profit. Tax tips. \$12.95 plus \$2 P & H. WOMACK, Box 1651, Melbourne, Fla. 32902. 8-85-4t

TUBES FOR TV AND RADIO—35¢ ea. Washington TV Service, 1330 E. Florence Ave., Los Angeles, CA 90001. 11-84-12t

FREE CATALOG. 99¢ KITS. Audio, video, TV, computer parts. Allkit, 434 West 4th St., West Islip, NY 11795. 5-85-6t

FULL LINE of TV converters. Wireless and manual compatible to Jerrold and Oak Systems. This month's special the Technica 140CHL stereo and video compatible out-put wireless converter. The only unit with a wireless volume control adjustment only \$159; cable 15dB Amp in-line type only \$20. **RED COAT ELECTRONICS**, new address and phone: 104-20—68th Dr., Forest Hills, NY 11374, Tele: (212) 459-5088. Catalogue \$3 for specials. 10-84-tfn

NLS 15 MHZ. miniscope with carrying case. \$240. Scarcely used. W. Roper, 2005 Southern Oaks, Austin, TX 78745. 9-85-1t

GAW FM SIGNAL GENERATOR Model 1012 with digital read-out, like new. Will take best offer. 501-584-4002, 501-642-3758 evenings. 9-85-1t

CABLE TV CONVERTERS & EQUIPMENT. Plans and parts. Build or buy. FREE information. C&D Electronics, 626 Flowerdale, Dept. EST, Ferndale, MI 48220. 8-85-1t

WANTED

BOUGHT/SOLD: Sams photofacts, gold & silver coins, VHS movies, all ratings, IBM/Apple computer software. Astro, Rt. 9W, Stony Point, N.Y. 10980, 914-942-2173. 6-85-4t

HELP WANTED

CAMERA-VIDEO Technicians needed. Top pay and benefits for well trained and experienced technicians who are expert with consumer and/or industrial cameras and VCR's. Training by manufacturers such as Sony, Hitachi, Panasonic, etc., are necessary for job experience. Come to sunny Florida and enjoy your work & leisure time. Write or call **ATLANTIC ELECTRONICS INC.**, 1881 NE 26 St., Ft. Lauderdale, FL 33305. (305) 564-8274 10 AM to 6:30 PM. Ask for Dave or Joe. 8-85-tfn

BUSINESS OPPORTUNITIES

PICTURE TUBE REBUILDING EQUIPMENT, one man operation, full training and technical assistance. Buy with confidence from experts in the field. Call or write: Chicago Television, 633 N. Semoran Blvd., Orlando, Florida 32807, Ph. 305-275-9543. 11-84-91

PHOENIX, ARIZONA Very busy TV Repair Shop. Rapidly growing area, excellent employees, \$60,000+ net. Terms available. Contact Mike or Vicki, VR Business Brokers, 935 E. Main, Mesa, AZ, 85203, Phone (602) 833-8923. 8-85-21

EXCELLENT OPPORTUNITY! TV shop, 50 years same location, 5 MILES FROM BEACH servicing W.L.A., Bev. Hills, & S.Monica. Established Clientele, Strong Lease. Tape Rental Potential. 1500 sq.ft., 40 K., 50/50 Finance. Hughes Radio & TV, 3347 Motor Ave., Los Angeles, CA 90034. Call John (213) 838-5051. 9-85-11

FLORIDA; TV SALES/SERVICE. COMMERCIAL ZONING! \$89,500 includes BUSINESS, LAND, BUILDING with Living QUARTERS. Assumable VA Mortgage. 812/822-4224 "Pauline" Realtors. 9-85-11

EDUC.-INSTRUCTION

UNIVERSITY DEGREES! Economical home study for Bachelor's, Master's, Doctorate. Prestigious faculty counsels for independent study and life experience credits. Free information—Richard Crews, M.D. (Harvard), President, Columbia Pacific University, 1415 Third St., Dept. 2B89, San Rafael, CA 94901; Toll Free: 800/227-1617, Ext. 480; California: 800/772-3545, Ext. 480. 9-85-11

**Use ES&T
classified
ads**

HELP WANTED

Television Technician Saudi Arabia

The King Faisal Specialist Hospital and Research Centre has a current opening for a Television Technician in the Audio-Visual Department. The AV Department is responsible for the educational and television needs of the Hospital's employees and their dependents. The Hospital is a 500-bed acute care facility located in Riyadh, Saudi Arabia.

Requirements include an Associate's degree in Electronics or 2 years trade school; 5 years experience including 2 or more years in maintenance and repair of TV and video systems. Candidate should have experience in industrial and broadcast grade equipment (three tube video cameras, camera control units, U-matic VTR, editing control, high resolution monitors, time base connectors, wave form monitor, victroscope, signal generator, cable TV system, etc.).

Salary and benefits are attractive and include: 30-day annual leave, furnished housing, transportation, bonus pay and more. Contracts are single status. The selected candidate will have a contract with the Government of the Kingdom of Saudi Arabia.

For further information and/or to apply, please send your resume to: **HCA International Company, Dept. ES-0985, P.O. Box 550, Nashville, TN 37202** or **HCA International Company, Dept. ES-0985, 500 Airport Blvd., Suite 110, Burlingame, CA 94010** or call toll-free (800) 251-2561. HCA is an Equal Opportunity Employer.

**HCA
International
Company**

ELECTRONIC

Servicing & Technology

Advertising Sales Offices

NATIONAL SALES MANAGER

Keith Willis
P.O. Box 12901
Overland Park, KS 66212
Phone: (913) 888-4664

SALES MANAGER

Greg Garrison
P.O. Box 12901
Overland Park, KS 66212
Phone: (913) 888-4664

ELECTRONIC SYSTEMS NEWSLETTER

Monthly publication written especially for the Hobbyist, Experimenter. Projects, Sources, New Ideas. FREE DETAILS.



AF Publishing Co.
Dept ST1
P.O. Box 524
So. Hadley, Mass. 01075

Circle (29) on Reply Card

**NEW
20-PAGE
CATALOG FREE**

7 MILLION TUBES

Includes all current, obsolete, antique, hard-to-find receiving, transmitting, industrial, radio/TV types. **LOWEST PRICES.** Major brands in stock. Unity Electronics Dept. E
P.O. Box 213, Elizabeth, N.J. 07206



Circle (28) on Reply Card

EXPERIENCE COUNTS! NON-RESIDENTIAL DEGREE PROGRAMS

Professionals in any field may apply for at-a-distance Bachelor's, Master's or Doctoral degree programs in Management, documenting work experience instead of further classwork, and presenting a career accomplishment project instead of a standard thesis. The cost is moderate; the time for completion is shortened. Designed for working professionals. Program authorized by the California Department of Education. Students Worldwide.

CALIFORNIA UNIVERSITY FOR ADVANCED STUDIES

School of Professional Management
Office of the Dean, Room EL-1
100 Galli Drive
Novato, CA 94947 (415) 382-1600

Circle (30) on Reply Card

\$\$ ATTENTION \$\$ TECHNICIANS \$\$

"My 1 man shop grossed \$2,500 monthly until I adopted the ECS SUCCESS PLAN. I now gross \$250,000 yearly on a service only and have 5 techs in my new 14,000 sq. ft. shop. The best part is I only work 40 hours a week.
THE ECS SUCCESS PLAN is The Best Investment I've Ever Made.

Richard Duran
Electronics Shop Owner Tech



ELECTRONICS SERVICE CONSULTANTS
"WE GUARANTEE YOU CAN SUCCEED"
FREE INFO ON C.O.D. ORDERS



214-667-7328 (24 HRS.)

A DIV. OF VISAR INTERNATIONAL INC.

Circle (31) on Reply Card

Advertisers' Index

Reader Service Number		Page Number
29	A.F. Publishing Co.	69
5	B&K Precision Dynascan Corp.	3
1,17	Beckman Industrial Corp.	IBC,61
30	California University	69
	Chemtronics, Inc.	45-46
	Contact East	27-28
26	Cooks Inst. Elec. Engrg.	64
4	Cooper Group	1
24	Dandy Mfg. Co.	67
10	Diehl Engineering	17-18,19,45-46,47
20	E.S.I., Inc.	63
	ETA	64
	Gregory Thomas, Inc.	29-30
16	Hykon Mfg. Co.	59
	Jensen Tools Inc.	43-44
	Leader Instrument Corp.	43-44
14	MCM Electronics	57
15	Moody Tools	59
	NATESA	65
	NESDA	62,66
	NRI Schools	11,27-28
8	NTE Electronics, Inc.	21
22	Optima Electronics	66
	Pace, Inc.	27-28
9	Philips ECG	25
19	Projector Recorder Belt Corp.	63
	RCA	51
13	Howard W Sams & Co. Inc.	55
	Sears, Roebuck & Co.	35-38
2,3	Sencore, Inc.	BC
11	Simpson Electric Co.	49
23	Solder Absorbing Technology Inc.	67
12	A.W. Sperry Instruments Inc.	53
27	Sperry Tech, Inc.	64
	Tab Books	43-44
	Tentel	29-30,65
	Test Probes, Inc.	29-30
28	Unity Electronics	69
31	Visar Int'l. Inc.	69
25-	Wahl Clipper Corp.	58
	Zenith	IFC

Success is built on dreams...

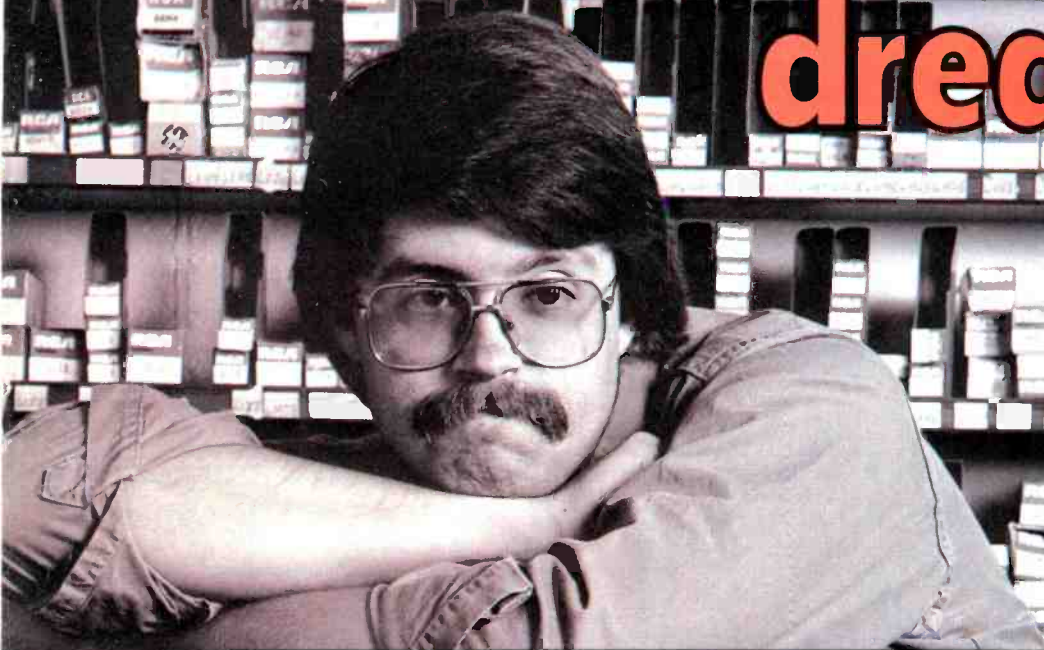

Join the Growing Sencore Team

SENCORE
the innovative leader of the electronic test instrument industry for over 30 years is looking for technical professionals.

Career opportunities exist in the following areas:

- Sales Representatives
- Electronic Engineers
- Technicians
- Application Engineers
- Technical Management
- Production Engineers
- Quality Control

If you feel you have interest in or the qualifications for any of these career areas, start your new career today by calling:

1-800-843-3338

and ask for the Human Resource Department or send a resume to:

Human Resource Dept. E
SENCORE
3200 Sencore Drive
Sioux Falls, SD 57107

EEO/AA Employers

Your Success is Our Success

Electricity and water don't mix. At least not in our Heavy Duty Digital Multimeters. Because these Oops Proof™ instruments are protected by a system of seals to ensure contamination-free dependability in even the cruddiest conditions.

Other abuse-proof features include the best mechanical protection ever built into a precision Digital Multimeter. In fact, every one of our Oops Proof multimeters will survive a drop from ten feet onto a concrete surface!

All the Heavy Duty series meters measure up to 1000 volts AC and 1500 volts DC, with full overload protection to those maximum voltages even on the lowest range settings. Overload circuitry also provides transient protection to 6KV on all voltage ranges and up to 600 volts on all resistance ranges.

We also invented a unique, long-life rotary switch for our Digital Multimeters. You can actually feel the difference just by

rotating the function selector knob.

You'll find these features in a full line of Heavy Duty DMMs that offer a 4½ digit readout, 0.05% VDC accuracy, a 10-amp current range, a 2000-hour battery life, diode test, true RMS and temperature measurement. All this and a no-questions, one-year warranty.

You'll want to try one out, of course, so drop into your nearest electronics distributor and drop one.

Our lips are sealed.



© 1985 Beckman Industrial Corporation, A Subsidiary of Emerson Electric Company,
630 Puente Street, Brea, CA 92621 (714) 671-4800.

Beckman Industrial™

Circle (1) on Reply Card

The people who gave you the Video Service Standard of the 70's. Now Introduce the all new standard for the 80's—MODEL VA62.



Cut your video service time in half

The Sencore VA48 TV Analyzer, introduced in 1976, quickly became the industry standard for video service. It is now used by more than 22,000 technicians nationwide who have averaged an overall 54% reduction in service time, according to a recent survey of VA48 owners.

But Times Change: Today's video circuits include projection TV, 4-head VCRs, SAW filters, comb filters, integrated flybacks, cable-ready tuners,

and many more circuits you just can't service effectively with the VA48. That's why we now have the VA62—the only video analyzer that equips you for all of these new video circuits—and then some.

In a Nutshell: Here's what makes the VA62 unique:

- It's a TV analyzer—Fully updated for the latest circuits.
- It's a VCR analyzer—Makes VCR analyzing a snap (using two inexpensive accessories) . . . and it meets all manufacturers' requirements.
- It's cable-ready—Test all the latest digital tuners.
- It has unique patterns—Special test patterns, plus standard pat-

terns simplify troubleshooting.

- It's obsolete proof—It can be updated as needed for new circuits or formats . . . quickly and inexpensively.

Guaranteed Results: The VA62 can cut your service time in half on all video circuits—new and old. We guarantee it or we'll refund your money at the end of 30 days.

Update Today: If you're ready to update your bench to service the new circuits of the 80's, write or call toll-free today for a complete color brochure.

TOLL-FREE 1-800-843-3338
In Canada Toll-Free 1-800-665-4871
South Dakota, Alaska, and Hawaii call collect at 605-339-0100.

Please send complete VA62 details:

Name _____
Address _____
City _____
State _____ Zip _____
Phone _____

(Mail to Sencore, 3200 Sencore Drive, Sioux Falls, SD 57107)

SENCORE

For Information Circle (2) on Reply Card
For Demonstration Circle (3) on Reply Card